

Operating Manual

Original Instructions



ER1000

These instructions belong with the vehicle



ER NEW Mini Telescopic Loader

Performance Parameters	
Rated Load	600kg
Bucket Capacity	0.3m ³
Lifting Height of main boom	2959mm
Dumping Height of main boom(dumping angle 45°)	2051mm
Dumping reach of main boom	587mm
Max. Loading capacity of main boom	1000kg
Lifting height of small boom	3526mm
Dumping height of small boom(dumping angle 45°)	2618mm
Dumping reach of small boom	1085mm
Max. Loding capacity of small boom	600kg
Max. Speed(F1/R1)	12km/h
Max. Traction force	16.66KN
Max. Breakout Force	15KN
Digging Deep	65mm
Max. Gradeability	25°
Max. Turning angle	35°
Dimension and weight	
Overall length(bucket on ground position)	3820mm
Overall width	1260mm
Overall Height	2310mm

EVERUN WE RUN TOGETHER WITH YOU!

Qingdao Everun Machinery Co.,Ltd

Adress: Room 902, Yongxin International Finance Centre, No.6 Qingling Road, Qingdao, China
Tel : 0086-532-80997859 Website : www.everun.cc Facebook : everunmachinery
Fax : 0086-532-80993178 Email : info@everun.cc Youtube : everunmachinery



Wheel base	1507mm
Tread	890mm
Min. Ground clearance	220mm
Net weight	2100kg
Engine	
Engine model	Yanmar 3TNV88F-ESSY
Type	Water cooled
Rated Power	19.2kw
Rated Speed	2200r/min
Max. Torque	98.7N.m
Speed at Max. Torque	1320r/min
Number of cylinders	3
Bore & stroke	88*90
displacement	1.642L
Rated fuel consumption	≤230
Transmission	
Pump Pressure	28MPa
Axle	bevel gear reduction
Main drive reduction ratio	3.75
Driving	4 wheel drive
Tire	26*12-12
Steering System	

EVERUN WE RUN TOGETHER WITH YOU!

Qingdao Everun Machinery Co.,Ltd

Adress: Room 902, Yongxin International Finance Centre, No.6 Qingling Road, Qingdao, China
Tel : 0086-532-80997859 Website : www.everun.cc Facebook : everunmachinery
Fax : 0086-532-80993178 Email : info@everun.cc Youtube : everunmachinery



Type	All hydraulic steering
System Pressure	16
Steering pump type	Gear pump
Steering diameter	63
Stroke	171
quantity	1
Braking System	
1) Foot Brake	
Type	Disc brake
Brake drum diameter	300
2) Hand brake (parking brake)	
Type	Drum
Brake Drum Diameter	160/120
Working hydraulic system	
Oil flow	13.8ml/r
Working pressure	16Mpa
Tilting cylinder diameter & stroke	∅80*318
Boom cylinder diameter & stroke	∅80*395
Voltage	12V
Battery model	6-QW-60B
Starter Type	electric

EVERUN WE RUN TOGETHER WITH YOU!

Qingdao Everun Machinery Co.,Ltd

Adress: Room 902, Yongxin International Finance Centre, No.6 Qingling Road, Qingdao, China
Tel : 0086-532-80997859 Website : www.everun.cc Facebook : [everunmachinery](https://www.facebook.com/everunmachinery)
Fax : 0086-532-80993178 Email : info@everun.cc Youtube : [everunmachinery](https://www.youtube.com/everunmachinery)

NOTES

General pages refer to all models mentioned in the header. Text that refers to particular models is marked correspondingly.

The engine Operating Manual must be observed.

CAUTION!

BEFORE STARTING THE VEHICLE THIS OPERATING MANUAL MUST CAREFULLY READ, UNDERSTOOD AND OBSERVED.

THE REGULATIONS AND LAWS VALID IN THE COUNTRY IN WHICH THE VEHICLE IS OPERATED MUST BE OBSERVED. INOBSERVANCE COULD CAUSE INJURIES OF FATAL ACCIDENTS. THE REGULATIONS OF THE TRADE CO-OPERATIVE ASSOCIATIONS ARE LAW.

USE OF THE OPERATING MANUAL:

This operating manual is a guide for safe operation of the vehicle.

**CAUTION!**

!!!A RESPONSIBLE DRIVER IS A SAFE DRIVER!!!

Before you use the vehicle, read this operating manual carefully. The safety instructions contained herein must be observed. Read the safety instructions regularly so that you do not forget them.

These instructions belong with the vehicle and must be always available.

If you have any questions, please contact your dealer or your nearest HERO TIME representative.

USE OF THE VEHICLE:

Your wheel loader can be used for various types of work. A thorough knowledge of the operating controls and their functions is a precondition for a safe and efficient use.

This operating manual is not an instruction book for loading work.

New drivers must always be appropriately trained before starting or operating the vehicle.

Without an appropriate training an efficient operation of the vehicle is not possible.

A risk of injury to the driver and other persons is also presented.

Operating Manual, Part A

Safety Instructions

Read Before Use



ER1000

These instructions belong with the vehicle

TABLE OF CONTENTS, PART A

1	GENERAL.....	6
1.1	Scope.....	6
1.2	Naming Definitions.....	6
1.3	Construction and Equipment.....	6
1.3.1	Identification and Marking.....	6
1.4	Operating Manual.....	7
1.5	Prevention against Unauthorized Use.....	7
1.6	Tubes and Pipes.....	7
1.7	Operation.....	7
1.7.1	Driver Requirements.....	7
1.7.2	Driving License Requirements for Loader.....	8
2	OPERATION.....	8
3	GUIDE.....	10
4	TRANSPORTATION OF PASSENGERS.....	10
5	PREVENTATION AGAINST TIPPING AND ROLLING OVER.....	10
6	PROTECTION AGAINST FALLING OBJECTS.....	11
7	OPERATION IN ENCLOSED SPACES.....	11
8	ACTIONS ON THE INTERRUPTION OF WORK.....	11
9	INSTALLATION,SERVICE,MAINTENANCE.....	12
9.1	Servicing.....	12
9.2	Towing, Transporting.....	12

9.3 Modifications and Welding Work.....	13
9.4 Roll-over Protection Structure (ROPS).....	13
10 MONITORING.....	14
10.1 Control.....	14
10.2 Testing.....	14
11 GENERAL SAFETY INSTRUCTIONS.....	15
11.1 Attachments.....	15
12 PROPER USE.....	17
13 WARNING SYMBOLS-SYMBOLS D'AVERTISSEMENT-WARNBIDZEICHEN.....	19

General

1.1 Scope

These safety instructions apply to loaders, dozers, diggers and special machines that are referred to as loader. This induces their attaching parts.

The ambient temperature of the loader working is -20~46°C.

The storage temperature of the loader is not required, but before long time storage, the coolant must be drained from the engine.

1.2 Naming Definitions

Loader

In these safety instructions, are vehicles with attachment tools to loosen, scoop, transport and drop earth, stones and other materials, whereby, the transport of the load is mainly performed by moving the loader.

Dozer

In these safety instructions, are vehicles with attachments that can loosen, pick up, transport and deposit earth, whereby, the material is not transported.

Digger

In these safety instructions, are vehicles with digging attachments that can loosen, pick up, transport and deposit earth, whereby, the loosening a picking up of earth is achieved through movement of the attachment.

Special Machines

In these safety instructions, are vehicles or equipment to load, move, transport or level earth or stones, whereby, according to its construction, this type of vehicle can only be used for special earth moving work.

1.3 Construction and Equipment

1.3.1 Identification and Marking

Every loader must have a durable identification plate with the following information on it:

- Manufacturer
- Year of manufacture
- Model number
- Type

On loaders that are centre-pivot steered, additional signs that contain the following information must be placed where they are clearly visible in the area of the centre-pivot.



CAUTION!

STANDING IN THE AREA OF THE CENTRE-PIVOT IS STRICTLY FORBIDDEN!

1.4 **Operating Manual**

An operating manual must be available for each loader. It must contain information for the safe operation of the vehicle that is presented in a clear and easily understandable form. The instructions must be presented in the language of the country in which the vehicle is operated.

The operating manual must always accompany the vehicle, or, be available in the operating environment.

1.5 **Prevention against Unauthorized Use**

The use of unattended loaders must be prevented. This can be achieved by removing the ignition key or locking the vehicle.

1.6 **Tubes and Pipes**

Tubes and pipes on loaders must be installed so that eventual mechanical and thermal damage is avoided. **Tubes and pipes must always be inspected prior to using the vehicle.**

Tubes and pipes in the area of the driver and operating areas, must be installed or covered so that the driver cannot be injured if a tube or pipe bursts.

The existence and affectivity of this safety measure must be checked before every use.

1.7 **Operation**

Loaders may only be properly operated through observation of the manufacturer's operating manual.

1.7.1 **Driver Requirements**

Driving or servicing of loaders may only be performed by persons who:

1. Are 18 years of age.
2. Are physically and mentally fit.
3. Have been instructed on how to drive or service earth moving machinery and have proved their competence to the employer.
4. It is to be expected from, that they can reliably perform the tasks with which they have been entrusted.

They must have the permission of the employer to drive or service the loader.

1.7.2 Driving License Requirements for Loader

For driving on public roads:

Wheel loaders with up to 20 km/h

Maximum speed according to construction type

Do not require registration and can be driven with a class L driving license. The only requirement is an operation permit, in which the vehicle is entered as a "self-driving working vehicle". The operation permit is given by the vehicle registration office. The operator is responsible to affect a corresponding policy of insurance. He has to settle with the insurance company whether the wheel loader is insured via the company liability insurance or whether a separate liability insurance is required.

Wheel loaders with over 20-25km/h

Maximum speed according to construction type

May also be driven with a class L driving license, however, they must be registered for road use. For this, an official number plate (green) and a vehicle third party insurance is required.

Wheel loaders with over 25-40km/h

Maximum speed according to construction type

Vehicles with up to 3.5t permitted maximum weight are only allowed to be driven on open roads with a class B driving license. Vehicles with over 3.5t and up to 7.5t permitted maximum weight are only allowed to be driven on open roads with a class C and class T driving license.



CAUTION!

**DIFFERENT REGULATIONS MAY APPLY IN OTHER COUNTRIES!
PLEASE OBTAIN THE APPLICABLE INFORMATION BEFORE USING THE
VEHICLE.**

2 Operation

1. The driver must restrict the vehicle speed to the applicable environmental conditions, so that the vehicle can be stopped at all times and cannot be turned over.
2. During vehicle movement, the driver must ensure at all times that the attachments remain as close to the ground as possible.
3. On particularly steep slopes and inclines, the load must be kept on the upward slope side of the vehicle.
4. Freewheeling (driving with the clutch depressed), is not permitted on downward

slopes. On loaders without a load adjustable gearbox, the appropriate gear for the conditions is to be selected before driving a downward slope, and is not to be changed during the vehicle movement.

5. The driver must apply the seat belt at all times when operating loaders, dozers and diggers with roll protection.
6. Never drive backwards with the accelerator fully depressed, make sure that the speed is always appropriate to the prevailing conditions.
7. Operating the drive-direction switch during operation can lead to accidents. The loader will drive, without warning, in the opposite direction.
8. Operating controls are only allowed to be operated from the driver's or operator's position. Before leaving the vehicle, the driver must lower the load arm, set all control-valves to the neutral position and apply the brake.
9. The driver is only allowed to work with the loader when no persons are present in the danger areas.
10. The driver must display warning signs when a danger for persons is present.
11. The driver must be aware of soft ground, electrical cables (exposed and sub surface), gas and water pipes. He must mark the position of underground cables and pipes and leave sufficient distance between himself and exposed electrical cables and buildings.
12. Collapsing materials can cause accidents e.g. avoid loading in front of a high wall or digging below walls.
13. During vehicle mounting and dismounting, you must always face the direction of the vehicle. Make sure that foot steps and shoe soles are clean and dry. Do not jump from the vehicle. Do not hold on to vehicle levers, but instead, on to the vehicle handrails.
14. Incorrect working clothes can lead to injuries, as loose clothing can become caught on parts of the vehicle. You should always wear appropriate protective clothing during your work; this includes a protective helmet, overalls, ear protection and gloves.
15. Turn spotlights off when you drive on public roads to avoid blinding other road users.
16. Before driving on public roads you must make sure that the vehicle equipment (lighting equipment etc) complies with the rules of the motor vehicle construction and use regulations, and, that the vehicle has a certificate to operate from the motor vehicle testing authority. With this certificate to operate, the vehicle is accepted as a self-driving working vehicle.

3 Guide

1. If the driver's vision is restricted in his working area due to influences on the working conditions (obstructions), he must be guided, or the working area must be cordoned off.
2. Only reliable personnel are permitted to be employed as a guide. They must be trained in their tasks before beginning their responsibilities.
3. Hand signals must be established to enable good communication between the driver and guide. The signals are only to be given by the driver and guide.
4. The guide must be clearly visible at all times. He must remain within the driver's field of vision.

4 Transportation of Passengers

1. Drivers of loaders are only allowed to carry passengers in areas in which the transporting of passengers is permitted by the manufacturer.
2. Loaders may only be mounted or dismounted after permission has been granted by the driver and the vehicle has been brought to a halt.
3. Passengers are not permitted to be transported on the vehicle's working attachments.
4. Loader attachments may not be used as a platform.

5 Presentation against Tipping and Rolling Over

1. To avoid the danger of tipping over, earth moving vehicles must always remain at a safe distance from the edges of crumbling land, excavations, mounds and slopes. The employer, or his appointed deputy, must determine the safe distance from such danger areas according to the firmness of the underlying ground.
2. Earth moving vehicles must be secured against the danger of rolling or slipping when used in the vicinity of trenches, shafts, graves, slopes and banks.
3. Loaders are only permitted to be used in dedicated tipping areas, when installations in the tipping area are present that prevent the vehicle from running off or crashing.

6 Protection against Falling Objects

1. When a danger of falling objects is present, earth moving vehicles must be fitted with a resistant protective roof for the driver's or operator's positions.
2. When undertaking earth or rock movement in quarries or trenches, diggers are to be positioned so that the driver's position and access to the driver's position are not on the wall side of the vehicle.
3. For the transport of large bail, see page 22.

7 Operation in Enclosed Spaces

In enclosed spaces, loaders that are driven by a combustion engine are only allowed to be used when they have a low exhaust emission.

Engines must be operated and serviced so that exhaust emissions remain as low as possible. When loaders with a combustion engine are operated in closed rooms, you must make sure that the room has a sufficient air flow (opening of windows and doors etc) so that a good supply of breathable air is constantly present.

8 Actions on the Interruption of Work

1. Before leaving the driver's(operator's)position, the driver(operator)must ensure that:
 - the attachments are turned off and
 - Unintentional movement of the vehicle is prevented through engaging the safety measures designed to prevent such movement.
2. If the driver leaves the vehicle, in addition to the requirements of paragraph 1 above, he must ensure that use of the vehicle by unauthorized persons is sufficiently prevented.
3. During breaks and on the cessation of work, the loader driver must ensure that the vehicle is on hard and even ground; in sloping areas the vehicle must also be prevented from rolling or slipping.
4. Never leave the vehicle in unsupervised areas. Accidents can be avoided through the erecting of warning barriers in public areas or when vision is reduced (e.g. at night).

9 Installation, Service. Maintenance

9.1 Servicing

1. Loaders may only be loaded, transferred or removed in accordance with the operating manual and under the supervision of a qualified person who has been appointed by the employer.
2. Loaders must be sufficiently braked during installation work, servicing and maintenance.
3. The engine must be switched off before all servicing and maintenance work. This may only be contravened when the servicing or maintenance work cannot be performed without the engine being on.
4. Before any servicing and maintenance work on non-isolated electrical equipment is carried out, the loader's engine must be disconnected from the battery or starter motor to avoid an inadvertent starting of the engine.
5. Servicing and maintenance work may only be carried out when the working equipment has been prevented from moving through placing on the ground, supporting or equivalent procedures.
6. During servicing and maintenance work the centre-pivot joint must be locked. Standing in the area of the centre-pivot is strictly forbidden when the engine is running.
7. The circuit diagram must be observed when electrical parts are connected or disconnected. Incorrect connection can lead to damage.

9.2 Towing, Transporting

1. Loaders may only be towed with an approved tow bar or rope, together with suitable equipment for the connection of tow bars and ropes to the loader.
2. Drive slowly when towing. Persons are not permitted to stand in the area of the tow bar or rope.
3. Loaders are only permitted to be towed when the brake system and steering are fully functional.
4. During loading or transporting of loaders, aids are to be used to prevent the inadvertent movement of the loader. The loader is to be kept free from mud, snow and ice so that ramps can be negotiated without the danger of slipping.

9.3 Modifications and Welding Work

Technical modifications are not permitted to be undertaken by the vehicle operator without the express permission of the manufacturer. Some machine parts are made of cast-iron. Welded joints in cast-iron can lead to weak points or cracks.

9.4 Roll-over Protection Structure(ROPS)

The vehicle is equipped with a Roll-over Protection System(ROPS). Working with a damaged ROPS can lead to serious accidents. A modified or improperly repaired ROPS is also dangerous. After an accident, a ROPS is only to be repaired by an approved person.

The EC permits the delivery and operation of vehicles that do not have roll protection if accepted by the relevant employer's liability insurance association. This is entirely dependent on the type of terrain on which the vehicle is to be used. Before the removal of roll protection, or, before buying a vehicle without roll protection, the permission from the governing employer's liability insurance association must be obtained.

In case of any part of the ROPS is affected by a plastic deformation and or rupture (e.g. by roll-over, tip-over or object impact), the ROPS has to be replaced according to manufacturer's specifications.

10 Monitoring

10.1 Control

1. The driver must check the correct function of the controls before every shift. He must also visually inspect the loader for any obvious faults.
2. The driver must check the correct function of the brake and the limit installation and limit warning device before using the hoist.
3. The driver must report any problems found to his superior, he must also inform his relief driver of any problems
4. Where faults mean a deterioration of the operating safety of the loader, the loader is not to be operated until the problem has been cured.
5. You must perform the following checks when the vehicle has been standing for a long period of time. We recommend that you also carry out these checks after particularly long shifts.



CAUTION!

THE CHECKS HELP TO ENSURE THE FUNCTIONAL ABILITY OF THE VEHICLE AS WELL AS YOUR OWN SAFETY.

- Check the following items for cleanliness and damage:
- Rods, cylinder, rod eye-ends, radiator
- Handrails and footsteps
- Make sure warning signs are present
- Inspect the engine for signs of damage or missing parts
- Check working attachments for completeness
- Check rod eye-ends and joints for condition and rigidity
- Check the engine for oil, fuel and antifreeze
- Check all screws for security of attachment
- Check tyre pressure

10.2 Testing

1. Loaders must be inspected by a trained person prior to first operation (commissioning), and, before being put into operation after major modifications.
2. Loaders should be inspected by a trained person (approved workshop) once a year. They should be inspected by a trained person (approved workshop) once a year. They should also be inspected at more regular intervals by an appropriately trained person depending on their operating conditions and prevailing circumstances.
3. The inspection results must be recorded in writing and kept at least until the next inspection.

11 General Safety Instructions

11.1 Attachments

Only use HAIYATE approved attachments for your vehicle.

Attachments may only be installed and operated after the applicable operating manual has been carefully read and understood.

Before use, it must be ascertained through practice, that the operating person is familiar with the attachments, the controls and their function.

Remember:



SAFETY FIRST

For all work, the appropriate tool must be used for the job to be carried out. For example, if too big a shovel is used for heavy materials, this could weigh down the equipment causing undue stress which will ultimately shorten the vehicle life.

Before disconnection, the working attachment must be lowered to ground level and supported against falling over. If this is not done, the attachment could tip over and cause serious injury. You must exercise particular care on slopes and inclines.

Engine/Steering Failure:

The engine must be immediately turned off after an engine or steering failure.

Engine:

The engine cover may not be removed when the engine is running.

Spark Emission from the Exhaust:

Spark emissions from the exhaust or electrical installation can cause explosions or fires. Avoid working in closed environments where inflammable materials, steam or dust is present.

Only park or leave the vehicle in a place that is secured against fire.

Battery:

Batteries that contain frozen electrolyte can explode when used or charged. Working with a frozen battery is strictly forbidden. Fully charged batteries cannot freeze.

Battery Gases:

Batteries give off gases that can explode. Keep all sparks and naked flames away from batteries.

Closed rooms in which batteries are used or charged must have a sufficient supply of fresh air.

Never check the charged state by connecting the terminals together, always use approved test equipment instead.

Battery Connections:

The negative pole of the vehicle is connected to earth. When connecting the battery, the negative (-) cable is always connected last. When disconnecting the battery, the negative (-) cable is always disconnected first.

Diesel Fuel:

Diesel fuel is flammable. Keep naked flames away from the vehicle and never smoke in the vicinity of the vehicle when filling up or working on the engine. Turn the engine off when you fill up with fuel. You can avoid fires and burns by observing these precautions.

Petrol Mixture:

Never fill the vehicle with petrol, or mix petrol with diesel fuel. Petrol gives off highly inflammable fumes.

Hydraulic Oil:

A fine jet of hydraulic oil ejected under great pressure can penetrate the skin. Use a piece of card when you look for small leaks. If oil does penetrate the skin you must immediately seek the assistance of a doctor.

Hydraulic Pressure:

Hydraulic oil under system pressure can lead to serious injuries. Before the connection or disconnection of equipment the engine must be switched off and the lever selected to “pressure release of pipes”. Make sure that the engine cannot be switched on when a pipe is open.

Different high pressure pipes are used on **HAIYATE** vehicles. When demanding replacement pipes note the DIN (German Standard) number on the pipe or the connector.

Monitoring Equipment:

Working with the vehicle is not permitted when one of the control lights is not working.

When the engine is running no control lights may be illuminated. If this happens, turn the engine off immediately. Let the fault be immediately cured. The vehicle may only be operated once the failure has been cured.

Protection against Injuries by Metal Splinters:

You must wear protective glasses when driving bolts in or out. Flying metal splinters can cause serious injuries. Always use a soft face hammer or a brass drift.

Tyre Condition:

Exploding tyres can cause serious injuries. Do not work with damaged, incorrect or worn tyres.

Standing under Attached Parts:

Standing under attachments is not permitted.

Before each operation, the attachment must be lowered and the brake applied.

12 Proper Use



WHEEL LOADERS ARE NOT ALLOWED TO BE USED IN OPEN TERRAIN OR FOR CONSTRUCTION WORKS.

Loaders are not permitted to be used as towing vehicles for trailers or trailer equipment.

When used for works which do not fall within the responsibility of the agricultural trade cooperative association the valid regulations of the competent trade co-operative association have to be observed.

For further information please contact the trade co. operative association.

ER1000 loaders are built in accordance with current technology and technical safety standards.

However, dangerous situations can still arise when using our vehicles. Therefore, our loaders and attachments are only to be used in a technically perfect condition. The safety regulations must be strenuously observed, when failures arise, the use of the vehicle and attachments is to be immediately ceased, the vehicle may only be used again once the problem has BEEN CURED.

According to the rules for the prevention of accidents of the agricultural trade-cooperative association vehicles that are used to stack large bales have to be equipped with protective devices against falling objects(VSG3.1,paragraph13).

Some of our vehicles are fitted with devices to prevent driving off or starting, which should never be immobilized. If these devices are faulty, the vehicle is not to be used until the fault has been cured.

Compliance with the operating and servicing instructions and the servicing regulations constitute proper use of the vehicle.

Loaders are to be used exclusively for the breaking up, loosening, loading, stacking, moving and distribution of bulk and unit loads.

Palette forks are for the picking up, transportation, stacking and placing of unit loads and palletted materials.

Feed transport and **distribution appliances** are exclusively for the transportation, loading, and distribution of feed, silage and straw.

The **crocodile gripper** serves the safe transport of straw and dung and the breaking-up of compressed dung; as well as materials that could fall from a fork.

Other **special appliances** are to be exclusively used for the purpose for which they are designed.

Loaders are only permitted to be used on level ground, in yards, and-with the appropriate operating permission of the motor vehicle construction and use regulations-in suitable public areas. The maximum stable operating load must be observed.

**CAUTION!**

OPERATION IS STRICTLY FORBIDDEN ON SLOPES, OR, IF A DANGER OF TIPPING OR FALLING OBJECTS IS PRESENT.

A DANGER OF FIRE THROUGH SPARKS IS PRESENT WHEN OPERATING IN THE VICINITY OF FLAMMABLE MATERIALS(HAY,STRAAW,PAPER ETC).IN SUCH ENVIRONMENTS,HOFTRAC AND WHEEL LOADERS ARE ONLY TO BE USED IN ACCORDANCE WITH THE PERTAINING LEGAL DIRECTIVES.

CAUTION

During the transportation of bails, **NEVER** transport more than one bail at a time. Falling bails can cause serious injuries.



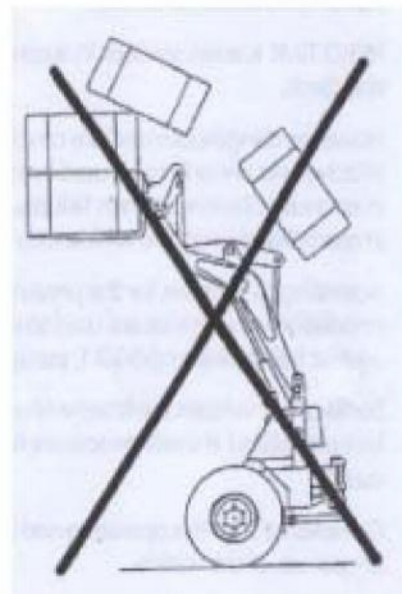

You must work with great care at all times.

The manufacturer also offers special stacking equipment and safety appliances. These include:

- Round and oblong bail stackers
- Round and oblong bail stacking appliance cabin
- Driver's cabin
- Driver's protective cabin
- Bail protection bar(can be retro-fitted)

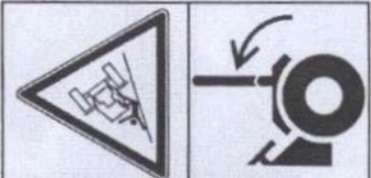

13 Warning Symbols

SYMBOLS	EXPLANATION
	<p>Stay clear of articulation area while engine is running.</p>
	<p>Attach support before getting into hazardous area.</p>
	<p>Never reach into rotating auger.</p>
	<p>Do not open or remove safety shields while engine is running.</p>
	<p>Stay clear of raised boom and bucket.</p>
	<p>If the working conditions permit, the roll bar must always be locked in safety position.</p>

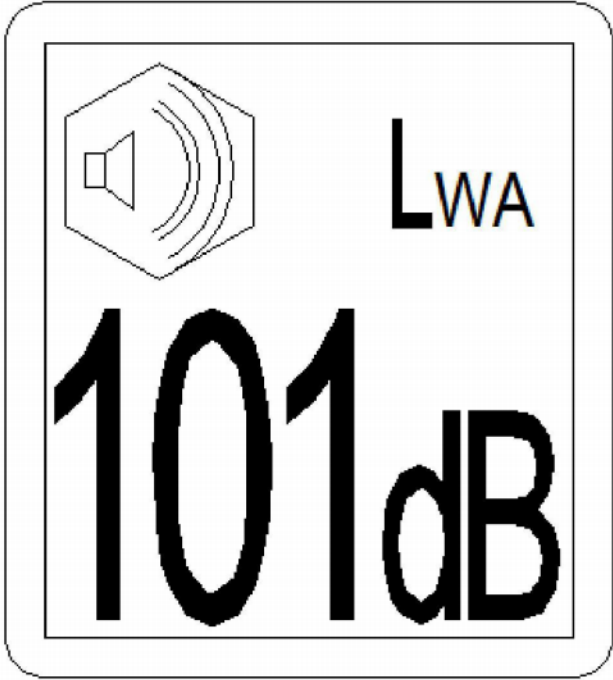
 <p>The image shows a noise symbol within a rounded rectangular border. On the left is a speaker icon with sound waves. To its right is the text 'LWA'. Below these elements is the value '101 dB' in a large, bold font.</p>	<p>Noise symbol</p>

Operating Manual, Part B

Description and Operation



ER1000

These instructions belong with the vehicle

TABLE OF CONTENTS, PART B

14	Operating Levers and Instruments.....	25
14.1	Operating Lever.....	25
14.2	Multifunction Lever.....	26
14.2.1	Drive Switch.....	26
14.3	Control and Warning Lights.....	27
14.4	Switches and Buttons.....	29
14.5	Switches and Buttons Optional Extras.....	30
15	Mechanic Quick Change System for Tool Attachments.....	31
15.1	Coupling.....	31
15.2	De-coupling.....	32
16	Operation.....	33
16.1	Before Getting into the Vehicle.....	33
16.2	Adjustment of the Driver's Seat.....	33
16.3	Safety Belt.....	34
16.3.1	Putting on the Safety Belt.....	34
16.3.2	Detaching the Safety Belt.....	34
16.4	Battery disconnecting switch.....	34
16.5	Before Switching on the Engine.....	35
16.6	Starting the Engine.....	36

16.7	Preparation for Road Use.....	37
16.8	Departure.....	37
16.9	Parking the Vehicle.....	39
16.10	Departure.....	40
16.11	Inching.....	41
16.12	Change of Drive Direction.....	41
16.13	Parking the Vehicle.....	42
16.14	Working at High Temperatures.....	42
16.15	Operation at Low Temperatures.....	43
16.16	Fuel System.....	44
16.16.1	Fuel Types.....	44
16.16.2	Fuel Filter.....	44
16.16.3	Fuel for Low Temperatures.....	44
16.16.4	Petrol.....	45
16.16.5	Refueling.....	45
16.16.6	Draining of Deposits from the Fuel Tank.....	45
17	Optional Ancillary Equipment.....	46
17.1	Introduction.....	46
17.2	Light Material Shovel/Earth Shovel.....	47
17.2.1	Safety.....	47
17.2.2	Installing the Load shovel.....	47
17.2.3	Operation.....	47
17.2.4	Operating Devices.....	47
17.2.5	Working with the Load Shovel.....	48
17.3	Crocodile Gripper.....	50
17.3.1	Safety.....	50

17.3.2	Working with the Crocodile Gripper.....	50
17.3.3	Installing the Crocodile Gripper.....	50
17.3.4	Operation.....	50
17.3.5	Operating Element.....	50
18	Towing.....	51
18.1	Towing over Longer Distances.....	51
18.2	Towing over Shorter Distances.....	51
18.2.1	ER1000.....	51
18.2.2	ER1000.....	51
19	Transport and Lifting	52
19.1	Transport	52
19.2	Lifting	53
20	Technical Data.....	53
20.1	Engine.....	53
20.2	Dimensions.....	55

14 OPERATING LEVERS AND INSTRUMENTS

14.1 Operating Lever

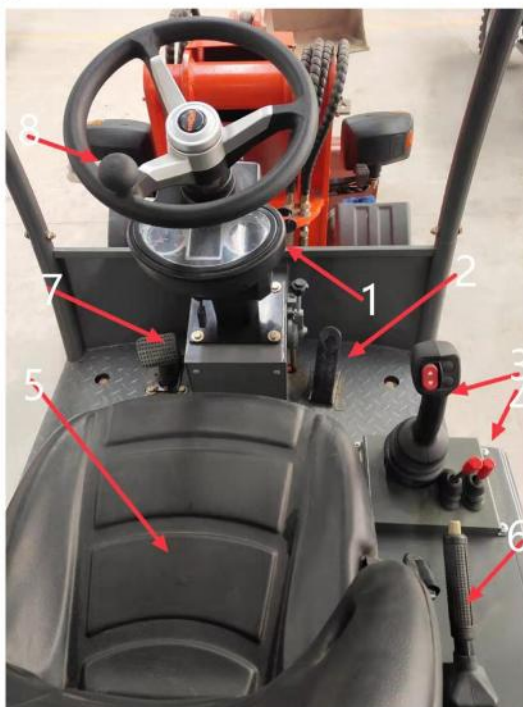

- 1、 Instrument panel
 - 2、 Accelerator pedal
 - 3、 Operating lever for load arm/drive
 - 4、 Operating lever for additional hydraulic equipment connection.
 - 5、 Driver's seat
 - 6、 Parking brake
- To apply the parking brake, pull the lever up. Push the button and lower the lever to release the brake. When the button is released, the control light goes off. When parking the vehicle, the parking brake must always be applied.
- 7、 Inch pedal
 - 8、 Steering wheel turning knob

After cold start the idle speed RPM can be increased slightly with this screw. **Set the desired engine RPM with the accelerator pedal and then fix the set position with the setting screw.** When the system runs smoothly (system warm), reduce the idle speed RPM. A high idle speed can cause accidents as the loader starts immediately after the throttle pedal has been operated.

The movement of the steering control corresponds to the intended direction of steering.

14.2 Multifunction Lever

The multifunction-lever is mounted on the operating lever of the control valve. The load arm is operated by moving the lever, the drive is selected by operating the switch.

14.2.1 Drive Switch

- Press the switch forward to select the forward drive direction
- Press the switch rearward to the neutral position to select the neutral drive direction.
- Press the switch rearward to select the rearward drive direction.
- Change into neutral position by pushing the rocker switch forward again.

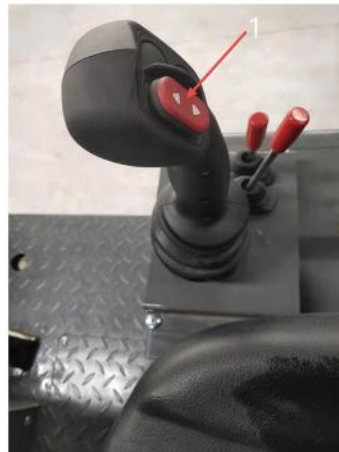

The drive direction is indicated on the display.



CAUTION!

OPERATING THE DRIVE-DIRECTION SWITCH DURING FAST DRIVE CAN CAUSE ACCIDENTS.THE VEHICLE WILL DRIVE SUDDENLY IN THE OPPOSITE DIRECTION.APPLYING THE PARKING BRAKE WILL CAUSE THE VEHICLE TO STOP.CONSULT A QUALIFIED OPerson BEFORE DRIVING THE VEHICLE FOR THE FIRST TIME.

WHEN YOU DRIVE THE VEHICLE FOR THE FIRST TIME, CHOOSE A LARGE, FLAT AREA.

14.3 Control and warning lights

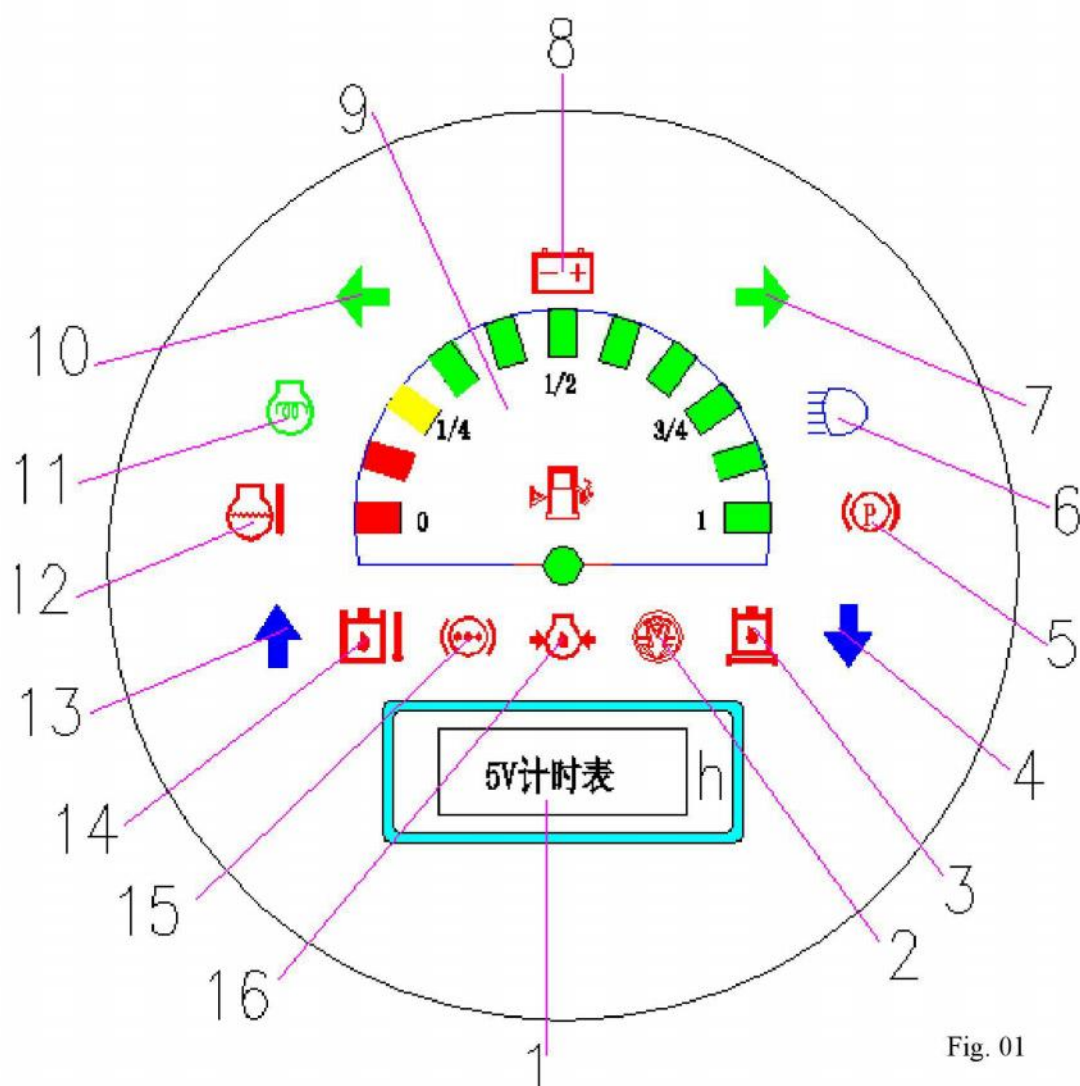

Fig. 01

ITEM	DESIGNATION	FUNCTION	SYMBOL
1	Operating time counter	Calculates the operating time of the vehicle. Maintenance and inspection have to be scheduled based on the reading of the counter.	See fig. 01
2	Air filter blocking warning light	Illuminates when the air filter is blocked.	See fig. 01
3	Oil contamination warning light	Illuminates when the engine oil is contaminated seriously.	See fig. 01
4	Rearward drive control light	Rearward drive-direction	See fig. 01
5	Parking brake control light	The parking brake has been applied.	See fig. 01
6	Front spotlight rocker switch	Push the switch downward to switch on the front spotlights.	See fig. 01

7	Right steering control light	right steering	See fig. 01
8	Generator warning light	Illuminates when the battery has not been charged.	See fig. 01
9	Fuel gauge	Indicates the fuel level.	See fig. 01
10	Left steering control light	Left steering	See fig. 01
11	Glow plug control light	Illuminates when the engine is preheated.	See fig. 01
12	Water temperature warning light	Illuminates when the engine water temperature is approximately 112°C.	See fig. 01
13	Forward drive control light	Forward drive-direction	See fig. 01
14	Hydraulic oil temperature	illuminates when the hydraulic oil temperature is too high.	See fig. 01
15	Barometric pressure warning light		See fig. 01
16	Engine oil pressure warning light	illuminates when the engine oil pressure is too low.	See fig. 01
17	Preheating controller	Switch on the engine when the glowing filament glows.	See fig. 02
18	Front/back spotlights rocker switch	Push the switch downward to switch on the front or back spotlight.	See fig. 02

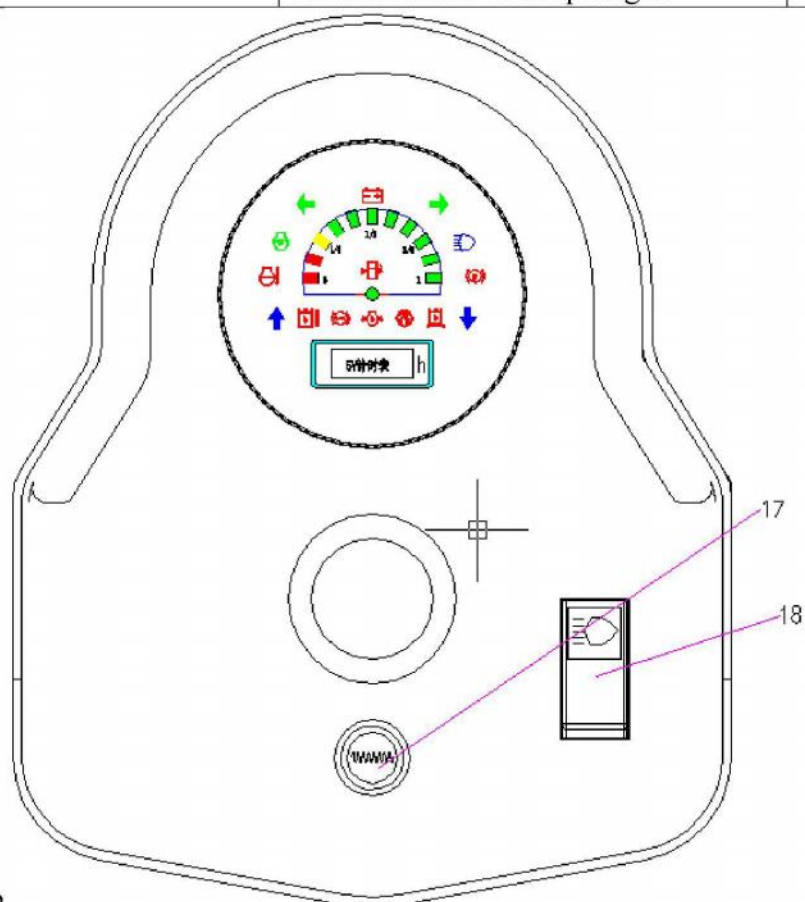

Fig.02

14.4 Lever for Load Arm

The lever [A] operates the arm and other tool attachments.

The single movements are executed as follows:

- rearward position-to raise the load arm
- forward position-to lower the load arm
- forward position(against resistance)-
to engage the floating position of the load shovel
- to the right side-to extend the shovel
- to the left side- to retract the shovel

For combined movements, the lever can be moved

between the four main positions. For example, to raise the shovel, pull the lever rearward and then push the lever to the left side to retract the shovel.

The working speed is dependant on the RPM of the engine and on the position of the lever.

The lever is returned to its neutral position from each position (except floating) by a return-spring.

When operating with floating selected, the shovel remains on the ground due to its own weight.

Depending on the ground conditions, the shove opposition moves to adapt to the ground unevenness.



14.5 Lever for Additional Hydraulic

To operate the “hydraulic connection of the load arm/hydraulic locking of the quick change system”, move the control lever (Fig.B) on the right side of the load arm lever, this lever returns automatically to its neutral position.

- lever in left position(L)-unlocked
- lever in right position(R)-locked

Operation of the hydraulic connection when the three-way cock is in the forward position:

- Lever in left position(L)
- left coupling under pressure
- return flow through right coupling
- Lever in right position(R)
- right coupling under pressure
- return flow through left coupling

During normal operation, the three-way cock remains in the “Locking” position, so that the tool attachments can be coupled or uncoupled from the driver’s position. The three-way cock is only moved if hydraulically operated tool attachments are to be used.

When the vehicle is equipped with an **electro valve** (optional extra) the level for the additional hydraulic equipment is omitted. In this case the hydraulic equipment is operated via the lower button of the multifunction lever. During normal operation the functions of the control lever are the same as described under item 1.6. If you want to use the functions of the additional control lever, press the lower button at the multifunction lever. During normal operation the functions of the control lever are the same as described under item 1.6. If you want to use the function of the additional control lever, press the lower button at the multifunction lever.



15 MECHANIC QUICK CHANGE SYSTEM FOR TOOL ATTACHMENTS

The vehicle is equipped with a mechanic quick change system, for different tool attachments, as standard. This allows the driver to make a quick and uncomplicated coupling and de-coupling of the attachments from his position.

The handle for the remote control of the mechanical quick-change system is located on the top left side of the arm spar. The operator can reach this handle without getting off the vehicle.



15.1 Coupling

Drive towards the tool attachment and push the quick change system of the vehicle into the receptacle of the attachment. Then lift the load arm and retract the attachment. Turn the lever of the locking bolt to the left. The locking bolt is pushed under spring pressure into the lock of the attachment. Make sure that the bolt has entered the lock.



CAUTION!

FOR HYDRAULICALLY OPERATED TOOL ATTACHMENTS, AFTER HAVING PICKED UP AND LOCKED THE TOOL ATTACHMENT, THE ENGINE MUST BE SWITCHED OFF. AFTERWARDS, MOVE THE OPERATING LEVER SEVERAL TIMES IN OTH DIRECTIONS, SO THAT THE HYDRAULIC CONNECTION IS WITHOUT PRESSURE.

Pass the hydraulic tubes through the eyes provided therefore on the attachment and the load arm, to the hydraulic connection. Remove the protective cap of the hydraulic rapid action coupling and make sure that the connections are clean. Plug the rapid action coupling into the connections of the additional hydraulic equipment. Put the protective caps together to prevent them from getting dirty. Check the hydraulic system of the tool attachment and the hydraulic rapid action coupling for tightness.

To do this, switch on the engine and move the tool attachment in both directions.



CAUTION!

A FINE JET OF HYDRAULIC OIL EJECTED UNDER GREAT PRESSURE CAN PENETRATE THE SKIN. DO NOT USE YOUR FINGERS WHEN LOOKING FOR SMALL LEAKS. DO NOT MOVE YOUR HEAD TOO CLOSE TO THE SUSPECTED SPOT. USE AN OPICEC OF CARD AND INSPECT IT FOR OIL. IF LIL DOES PENETRATE THE SKIN IMMEDIATELY CONSULT A DOCTOR.

15.2 De-coupling



CAUTION!

BEFORE DE-COUPLING, LOWER THE TOOL ATTACHMENT ON EVEN GROUND. ON UNEVEN GROUND TOOL ATTACHMENTS CAN TIP OVER RESULTING IN PERSONAL INJURIES.

Close the tool attachment and shut off the engine.

Move the operating lever for the additional hydraulic equipment several times in both directions to release the hydraulic connection of pressure.

Pull the locking bolt up and press it to the right to unlock the tool attachment.



CAUTION!

A SMALL QUANTITY OF OIL MAY ESCAPE WHEN YOU DISCONNECT THE HYDRAULIC RAPID ACTION COUPLING. COLLECT ANY OIL IN A SUITABLE CONTAINER TO PREVENT ENVIRONMENTAL POLLUTION (LEAK-FREE COUPLINGS ARE AVAILABLE AS AN OPTIONAL EXTRA).

Disconnect the hydraulic coupling and put on the protective caps. Draw the hydraulic tubes out of their conduits and place them over the tool attachment. Pull up the locking bolt and press it to the right. Set the tool attachment onto the ground, extend and lower the attaching frame.



CAUTION!

ONLY EXTEND THE ATTACHING FRAME UNTIL THE LOCK DOES NOT IMPEDE THE LOWERING OF THE ATTACHING FRAME.

16 OPERATION

16.1 Before Getting Into The Vehicle

Observe the daily maintenance schedule (see part C, Maintenance/Trouble Shooting). Do not hold on to the levers when getting in the vehicle.

 **ATTENTION! ONLY GET IN THE VEHICLE FROM THE LEFT SIDE.**

16.2 Adjustment of the Driver's Seat

The driver's seat can be adjusted as required to prevent strains and fatigue. Adjust the driver's seat so that all operating levers are easy to reach and the pedals can be depressed completely when you are seated with your back against recline.

The following adjustments are possible:

- forward/backward- adjustment(Fig.-1)
Pull the lever up, adjust the seat, and then push the lever down.
Make sure that the seat has completely engaged
- Weight adjustment (Fig.-2)
Push the lever down depending on the driver's weight.
Low weight:
Push the lever (Fig.-3) down completely and release.
The handle moves automatically up and the seat can be adjusted to the corresponding weight.



16.2.1 Vibration

The vibration total value to which the hand-arm system does not exceed 2.5m/s^2 .

The highest root mean square value of weighted acceleration to which the whole body does not exceed 0.5m/s^2 .

 **CAUTION!**

**ALWAYS PUT ON THE SAFETY BELT WHEN OPERATING THE VEHICLE.
EXCHANGE DAMAGED PARTS OF THE SAFETY BELT OR THE LOCK.**

16.3 Safety belt

16.3.1 Putting on the Safety Belt

Sit down correctly.

Pull the belt over your hips and engage the lock.

Do not adjust the belt too loose or too tight.

16.3.2 Detaching the Safety Belt

Press the button and remove the belt from the belt lock. Repair or replace damaged parts of the belt or the lock.

16.4 Battery disconnecting switch (Optional Extras)

The battery disconnecting switch is located under the engine cover and is used to disconnect the complete electrical system from the battery in case of an emergency (e.g. cable burning). We recommend to switch off the battery overnight to prevent a possible discharge of the battery of cable burning. If the switch head is pulled off, the switch can also be used as additional theft protection.

When the switch head is pulled off, the aperture must be imperatively covered with the protective cap, to prevent any moisture from penetrating into the switch.



CAUTION!

THE BATTERY DISCONNECTING SWITCH MUST NOT BE SWITCHED LOAD. BEFORE INSERTING THE IGNITION KEY, THIS SWITCH MUST FIRST BE OPERATED. FOR SWITCHING OFF PROCEED IN REVERSE ORDER.

16.5 Before Switching on the Engine

1. Apply the parking brake
After having parked the vehicle, the parking brake must always be applied.
2. Checks before starting the engine:
 - Walk round the vehicle(see " Before getting in ").
 - Remove dirt and waste from the driver's cabin.



CAUTION!

THE OPERATING ELEMENTS OF THE VEHICLE MUST ALWAYS BE CLEAN AND DRY.

1. Remove or fix all loose parts.
2. Check the driver's cabin for loose or missing screws, bolts etc. Insert or tighten, when necessary.
3. Verify the function of the following equipment:
Lights, control lights, signal horn, indicators, all switches, direction indicator, hazard lights, screen washer and screen wipers.
4. Adjust the driver's seat.
5. Put on the safety belt.
6. Push the forward/reverse drive lever into the neutral position.
The engine can only be started, when the drive-direction lever is in the neutral (-0-) position.

16.6 Starting the Engine

1. Before starting the engine, make sure that nobody is within the danger areas of the engine or the vehicle. After repair, check that all protective devices have been installed and all tools have been removed from the engine. Do not use any further starting aids (e.g. starting pilot).
Danger of accidents!
2. Depress the accelerator pedal.
3. Start the engine.
 - Insert the key-position 0=no operating voltage
 - Turn key left against spring pressure-position 3=Preheating
 - When the preheating controller illuminates
 - Turn key right-position 2=Starting
 - Release the key as soon as the engine starts. The key returns to position 1 and the control lights extinguish.



CAUTION!

AT TEMPERATURES BELOW 0°C, THE ENGINE TURNS AT A LOWER SPEED FOR A CERTAIN TIME DUE TO THE GREATER VISCOSITY OF THE HYDRAULIC AND ENGINE OIL THE LOWER THE AMBIENT TEMPERATURE, THE LONGER THE TIME REQUIRED FOR PREHEATING. TO AVOID DAMAGE TO THE ENGINE, DO NOT INCREASE THE RPM IMMEDIATELY. OBSERVE THE PRESSURE INDICATOR OF THE HYDRAULIC FILTER.

4. Use the engine RPM regulator to set the idle, and verify that all control lights have extinguished. Repair eventual faults.
5. RPM regulator:
After cold start the idle speed RMP can be increased slightly with this screw. **Set the desired engine RMP with the accelerator pedal and then fix the set position with the setting screw.** When the system runs smoothly (system warm), reduce the idle speed RPM. A high idle speed can cause accidents as the loader starts immediately after the throttle pedal has been operated.
6. Start without interruption for max. 20 seconds. If the engine does not start, repeat starting after one minute. If the engine fails to start again, look for the cause using the trouble shooter's guide (see Engine Operating Manual).

16.7 Preparation for Road Use



CAUTION!

BEFORE DRIVING ON OFFICIAL ROADS, MAKE SURE THAT THE VEHICLE CORRESPONDS TO THE APPROPRIATE REGULATIONS AND THAT THE DRIVER HAS A VALID DRIVING LICENCE.

1. Secure the tool attachments!
2. Attach the protective cover to the shovel.
3. The shovel must be empty and lifted into the transport position!
4. Check the lights!
Make sure that the headlights and the rotating light, if fitted, are in working order!
5. Set all hydraulic control valves to position O.
6. When driving on public roads the vehicle must have the corresponding certificates for road use.
7. Lock the operating lever!

16.8 Departure

After preheating the engine (IMPORTANT) and releasing the parking brake, start the vehicle as described below.



OPERATING INSTRUCTIONS

AFTER HAVING RELEASED THE PARKING BRAKE, THE VEHICLE IS STARTED BY DEPRESSING THE ACCELERATOR PEDAL THE VEHICLE MUST ALWAYS STAY UNDER CONTROL WHILE DRIVING [AY ATTENTION TO OBSTACLES AND POSSIBLE DANGERS.

DO NOT PLACE YOUR FEET ON THE BRAKE INCH PEDAL



CAUTION!

WHEN DRIVING, REGULATE THE ENGINE RPM WITH THE ACCELERATOR PEDAL ONLY. THE RPM MAY NOT BE ADJUSTED BY MEANS OF THE THROTTLE HAND LEVER.

16.8.1 Check the driver's seat and the safety belt

- Make sure that the safety belt is put on correctly.
- Make sure that the driver's seat is adjusted correctly.

a) Release the parking brake

b) Make sure that it is safe to drive off, then depress the throttle pedal into the desired drive direction.

Throttle pedal to the front = Forward drive

Throttle pedal to the rear = Rearward drive

The vehicle starts smoothly.

c) By operating the throttle pedal and the accelerator pedal the drive speed can be adjusted infinitely variable. To stop the vehicle depress the brake pedal and move the throttle pedal in the 0-position.

Drive slowly and monitor the steering and the brakes. Stop when steering or brakes are not working correctly. If in doubt, assume that there is a part or parts which are damaged.

16.8.2 Hydraulic overdrive

By operating the corresponding lever at the control valve for the lifting hydraulic the hydraulic overdrive is switched on. The tool attachment, however, cannot be lifted or retracted.

16.8.3 Stopping the vehicle

1. Decelerate
2. Move the throttle pedal slowly to the 0-position.



CAUTION!

THE HYDRAULIC SYSTEM HAS ONLY A POOR BRAKE FUNCTION. ALWAYS USE THE SERVICE=FOOT BRAKE WHEN A HIGHER BRAKE FUNCTION IS REQUIRED.

16.8.4 Change of drive direction

1. Decelerate.
2. When the vehicle has almost stopped, move the throttle pedal into the other drive direction.
3. Drive off.



CAUTION!

OPERATING THE THROTTLE PEDAL WHEN DRIVING CAN CAUSE FATAL ACCIDENTS OR PERSONAL INJURY.

16.8.4 Pushing Operation

The more the throttle pedal and the accelerator pedal have been depressed, the higher is the pushing force. The maximum pushing force is achieved just before the tyres start to slip.

16.9 Parking the Vehicle

- only in designated areas that are fire-protected.

1. Stop the vehicle
2. Apply the parking brake



CAUTION!

BEFORE SETTING DOWN THE TOOL ATTACHMENTS, MAKE SURE THAT NO PERSONS ARE WITHIN THE DANGER AREAS AS THIS COULD CAUSE FATAL ACCIDENTS OR PERSONAL INJURY.

3. Lower the tool attachments onto the ground.
After having lowered the tool attachments onto the ground, continue until the attachments start to bear the weight of the vehicle.
4. Stop the engine by turning the ignition key and remove the ignition key when you leave the vehicle.
5. Switch off all switches that are not required.
Before leaving the vehicle, make sure that all switches have been switched off. If required, hazard warning lights and/or the parking light may be switched on.
6. Getting out of the vehicle and securing the vehicle.
When getting out of the vehicle use the hand rails and the foot step.
7. When parking on inclines use a wheel chock.

16.10 Departure

OPERATING INSTRUCTIONS

AFTER HAVING RELEASED THE PARKING BRAKE AND CHOSEN THE DRIVE-DIRECTION, THE VEHICLE IS STARTED BY DEPRESSING THE ACCELERATOR PEDAL WHILE DRIVING, KEEP THE SHOVL NEAR TO THE GROUND TO ENSURE A GOOD VISIBILITY AND A HIGHER STABILITY OF THE VEHICLE THE VEHICLE MUST ALWAYS STAY UNDER CONTROL PAY ATTENTION TO OBSTACLES AND POSSIBLE DANGERS. DO NOT PLACE YOUR FEET ON THE BRAKE OR THE INCHPEDAL.



CAUTION!

WHEN DRIVING, REGULATE THE ENGINE RPM WITH THE ACCELERATOR PEDAL ONLY. THE RPM MAY NOT BE ADJUSTED BY MEANS OF THE RPM CONTROLLER (IF INSTALLED).

1. Release the parking brake.
2. Operating the drive-direction switch
Choose the speed according to the actual circumstances and the work to be done.
After having chosen the drive direction, the vehicle is only started when the parking brake (visual indication) has been released.
 - Make sure that the tool attachments are in the drive position. Release the parking brake.
 - Make sure that it is safe to drive off, and then depress the accelerator pedal. The vehicle starts smoothly.
 - Drive slowly and monitor the steering and the brakes. Stop when steering or brakes are not working correctly. If in doubt, assume that there is a part or parts which are damaged.

16.11 Inching

The speed of the vehicle is proportional to the accelerator pedal position.

- low engine RPM = low driving speed
- high engine RPM = high driving speed

The pump flow rate is infinitely variable and can be reduced by depressing the inch pedal on the left side of the steering column. Therefore, a very slow driving speed is also possible at a high engine RPM.

16.12 Change of Drive Direction

1. Decelerate.
2. When the vehicle has almost stopped, move the drive-direction switch into the other position.
3. Depress the accelerator pedal.

It is not necessary to operate the inch pedal at each change of the drive direction.



CAUTION!

OPERATING THE DRIVE-DIRECTION SWITCH AT A HIGH DRIVING SPEED CAN CAUSE FATAL ACCIDENTS OR PERSONAL INJURY. THE VEHICLE WILL DRIVE, WITHOUT WARNING, IN THE OPPOSITE DIRECTION.

16.13 Parking the Vehicle

- only in designated areas that are fire-protected
- 1. Stopping the vehicle
Stop the vehicle smoothly by releasing the accelerator pedal and gradually depressing the inch pedal. Then depress the foot brake.
- 2. Applying the Parking Brake
Pull up the parking brake lever. Make sure that the control light illuminates (visual indicator).



CAUTION!

BEFORE SETTING DOWN THE TOOL ATTACHMENTS, MAKE SURE THAT NO PERSONS ARE WITHIN THE DANGER AREAS.

- 3. Lower the tool attachments onto the ground.
After having lowered the tool attachments onto the ground, continue until the attachments start to bear the weight of the vehicle.
- 4. Stop the engine by turning the ignition key.
- 5. Remove the ignition key when you leave the vehicle.
- 6. Switch off all switches that are not required.
Before leaving the vehicle, make sure that all switches have been switched off. If required, hazard warning lights and/or the parking light may be switched on.
- 7. Getting out of the vehicle and securing the vehicle.
When getting out of the vehicle use the hand rails and the foot step. The tank cover should be locked. When parking on inclines use a wheel chock.

16.14 Working at High Temperatures

To avoid damaging the vehicle, take the following precautions when you work at high temperatures:

- 1. Use engine oil of the correct viscosity.
(see liquids, lubricants, volumes and specifications)
- 2. Use the correct coolant mixture.
- 3. Regularly check the radiator and the oil cooler.
Ensure the correct level of coolant. Make sure that there are no leaks.
- 4. Keep the radiator clean.
Regularly remove dirt from the radiator and engine. (*See chapter C "Cooling Systems"*).
- 5. Regularly check the fan belt and the oil cooler fan.
- 6. Regularly check the preliminary filter of the engine (if fitted).
Check the dust valve and remove dust if necessary (see engine air filter).

16.15 Operation at Low Temperatures

At low temperatures, take the following precautions to facilitate starting and to avoid damaging the vehicle.



CAUTION!

AT TEMPERATURES BELOW 0 ° C, THE ENGINE TURNS AT A LOWER SPEED FOR A CERTAIN TIME DUE TO THE GREATER VISCOSITY OF THE HYDRAULIC AND ENGINE OIL. THE LOWER THE AMBIENT TEMPERATURE, THE LONGER THE TIME REQUIRED FOR PREHEATING. TO AVOID DAMAGE TO THE ENGINE, DO NOT INCREASE THE RPM IMMEDIATELY. OBSERVE THE PRESSURE INDICATOR OF THE HYDRAULIC FILTER.

1. Use engine oil of the correct viscosity (see liquids, lubricants, volume and specifications).
2. Use fuel for low temperatures.
3. Use the correct coolant mixture.
4. Check if the battery is completely charged.
5. Top up the fuel tank at the end of each working shift.
6. Protect the vehicle during breaks.
7. Install a cold starting aid.
At low temperatures of -18°C or less, an additional starting aid, such as fuel, oil and coolant heaters, can become necessary. For an appropriate starting aid, please consult your local dealer or one of our representatives.



CAUTION:

DO NOT CONNECT TWO BATTERIES IN SERIES TO GENERATE A STARTING VOLTAGE OF 24 V. THIS MAY LEAD TO A BURNING OUT OF THE INTAKE MANIFOLD HEATER AND THE STARTER MOTOR.

16.16 Fuel System

16.16.1 Fuel Types

Diesel of high quality is a precondition for a correct engine performance.

16.16.2 Fuel Filter

A preliminary filter with water separator is installed before the fuel pump to eliminate large dirt particles. A plastic ring is located inside the casing of the preliminary filter. If this plastic ring floats, water has penetrated into the filter casing, and the casing, as well as the filter, have to be cleaned. Replace the fuel filter and the preliminary filter at regular intervals as specified. See the Engine Operating Manual!

16.16.3 Fuel for Low Temperatures

Use special winter fuel types at temperatures below 0° C. These fuel types have a lower viscosity and restrict the formation of wax in the fuel (the wax may impede the fuel flow through the filter). To reduce the formation of wax, it is also possible to add special agents which improve the fuel flow.

16.16.4 Petrol



CAUTION!

DO NOT USE PETROL FOR THIS VEHICLE. DO NOT MIX PETROL WITH DIESEL; THE PETROL RISES TO THE SURFACE INSIDE THE FUEL TANK AND GIVES OFF INFLAMMABLE VAPOURS. FUEL IS FLAMMABLE. KEEP THE VEHICLE AWAY FROM OPEN FLAMES. DO NOT SMOKE WHEN REFUELLING OR WHEN WORKING OR WHEN WORKING ON THE ENGINE. STOP THE ENGINE BEFORE FUELLING. IGNORANCE OF THESE INSTRUCTIONS MAY CAUSE FIRE.

16.16.5 Refueling

- Unscrew the cap of the filler neck.
- Top up fuel.

If possible use a fine filter in the filling line.

Use only clean fuel, as even the smallest dirt particles can cause rapid wear or malfunctions.

Use only fuel types of known brands, As the best method of cleaning fuel is through precipitation, the fuel should not be circulated after delivery and must be stored for at least one day. Do not keep opened barrels outdoors, as variations in temperature may result in heavy condensation. Use only winter fuel types at temperatures near and below freezing point (see Engine Operating Manual). Refueling out of large, stationary containers is recommended. Avoid as far as possible refueling from barrels. If you do, observe the following instructions:

1. To avoid disturbing deposited contamination, do not roll or tilt the barrels before refueling.
2. Protect the end of the refueling pipe with a fine-meshed sieve and keep it approximately 15cm away from the bottom of the barrel.
3. Topping up of the fuel tank should be done using a funnel sieve with cloth filter and a fine sieve in the tank neck of the vehicle.
4. Always keep the barrels used for refueling tidy. Gross negligence when refueling cannot be compensated by an efficient fuel filter, as this only separates the smallest impurities out of the fuel.

Top up the tank with the correct fuel type at the end of each day to avoid condensation during the night.

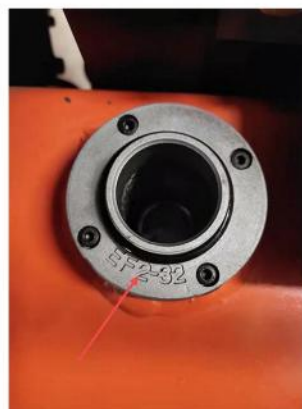

16.16.6 Draining of Deposits from the Fuel Tank

From time to time, water and deposits that have collected at the bottom of the fuel tank must be drained off. This is especially recommended at temperatures below freezing-point and in weather conditions that accelerate condensation. Before refueling, remove the drain plug at the bottom of the fuel tank and drain all deposits that have collected.

17 OPTIONAL ANCILLARY EQUIPMENT

17.1 Introduction

This part of the manual contains information on the optional HERO TIME ancillary equipment. Some of these are already installed on the vehicle. Contact the responsible representative when you are interested in further equipment.

Before installing, operating and servicing the equipment, read carefully the corresponding operating instructions of the manufacturer. Consult the responsible representative if you have any questions.

If the hydraulic system of your vehicle has to be modified for the use of ancillary equipment, consult our representative. The laying of hydraulic tubes has to be carried out by qualified personnel.



REMEMBER SAFETY FIRST

Use the appropriate tool for the job to be carried out. Do not use too big a shovel for heavy material, this could weigh down the equipment causing undue stress which will ultimately shorten the vehicle life.



CAUTION! REMEMBER THAT SNOW, LOOSE MATERIAL, AND MUD ALTER THE GROUND CONDITIONS, GROUND SUBSIDENCE OR COLLAPSING MATERIALS CAN CAUSE ACCIDENTS.

17.2 Light Material Shovel/Earth Shovel

17.2.1 Safety

Observe the safety instructions and the maximum admissible load capacities (see technical data).



CAUTION!

THERE ARE MANY DIFFERENT MATERIALS, EACH HAVING THEIR OWN SPECIAL PROPERTIES. USE THE LIGHT MATERIAL SHOVEL FOR LIGHT BULK MATERIALS, SUCH AS CORN, CONCENTRATED FEED STUFF ETC, AND THE EARTH SHOVEL FOR HEAVY BULK MATERIAL, SUCH AS GRAVEL, SAND ETC.

17.2.2 Installing the Load Shovel

See " Coupling of the Tool Attachments " .

17.2.3 Operating

Practice using the load shovel before first application.

Depending on the experience of the driver, the work to be done and the type of material, certain deviations from these instructions may become necessary.

17.2.4 Operating Devices

The load shovel is operated with the operating lever (see operating instructions). Use extreme care when operating the load shovel.

When emptying the load shovel and to load other vehicles it is recommended to execute two movements simultaneously, e.g. lifting and extending or lowering and retracting. To do this the movements on the control lever must be superimposed.

0	=	neutral position
1	=	lifting
2	=	lowering
2a	=	floating position
3	=	retracting
4	=	extending

The floating position is used to level a surface. Lower the point of the load shovel on to the ground. Engage the control lever in position 2a so that the load shovel lies on the ground, born by its own weight.

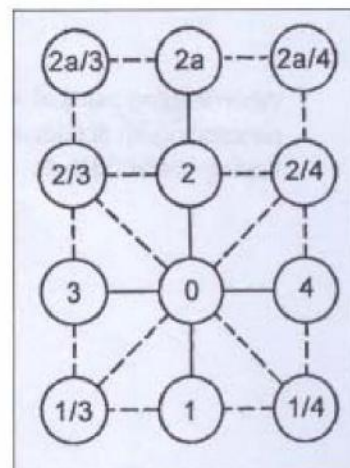

17.2.5 Working with the Load Shovel

To take up loose material, lower the load shovel and adjust the edge parallel to the ground.

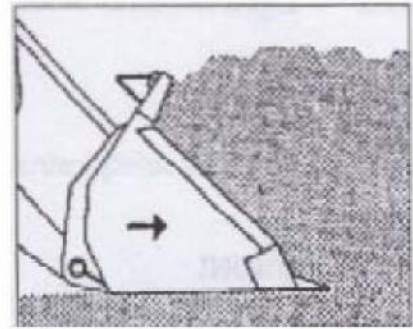

Now drive towards the material to be loaded. The driving speed depends on the type of material and the working conditions.

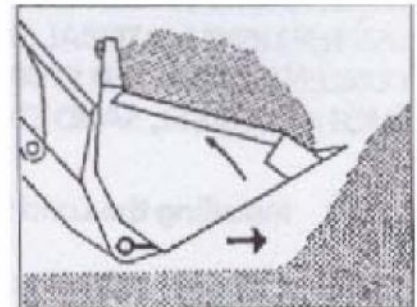

Lift the load arm slightly to load the front axle and to avoid a slipping of the tyres (also manually possible by " inching "). Retract the shovel when it is full.

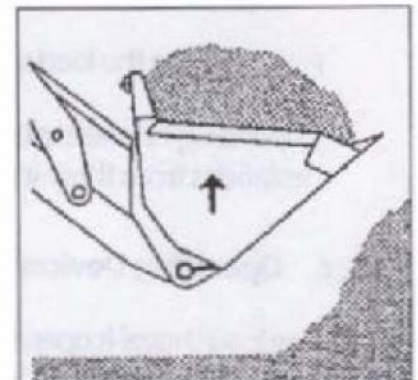

Retract the filled load shovel. Change the drive-direction and move the shovel in to the transport position to guarantee secure driving and steering.

When loading material the load shovel has difficulties penetrating, lift and lower the load shovel by operating the tipping operating lever.

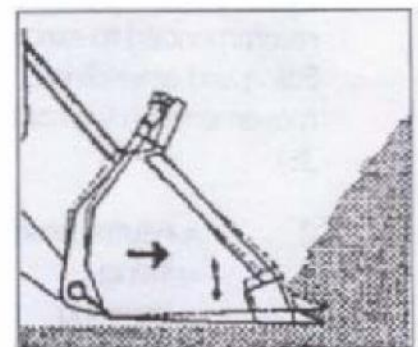

If the transport distance to the dumping place is relatively far, lift the shovel to a position where it does not touch the ground.



CAUTION!

TRANSPORTING WITH A LIFTED AND FULLY LOADED SHOVEL IS DANGEROUS; THE LOWER THE POSITION OF THE SHOVEL, THE MORE FAVOURABLE THE DISTRIBUTION OF VEHICLE WEIGHT. THIS IS ESPECIALLY IMPORTANT WHEN TURNING OR DRIVING.

To take up soft material, lower the shovel onto the ground and extend it until a digging angle has developed. Drive forward so that the edge of the shovel penetrates the ground. Afterwards, reduce the tipping angle to cut an even layer of ground and to avoid a slipping of the tyres.

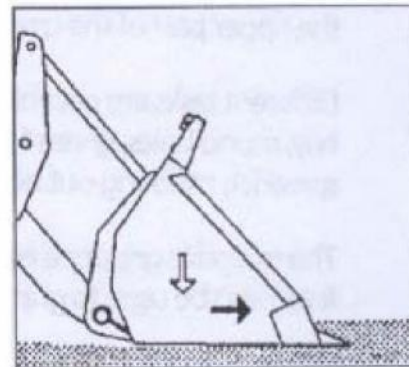

To take up hard material, lower the shovel onto the ground and extend until a digging angle has developed. When driving forward, press the shovel slightly downward, so that it penetrates the ground. Avoid an extreme slipping of the tyres. Then reduce the tipping angle, and, while driving forward, operate the tipping operating lever to lower and lift the shovel, and to load the front axle constantly.

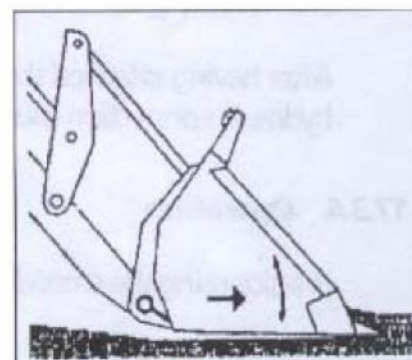

17.3 Crocodile Gripper

17.3.1 Safety

Observe the safety instructions as well as the maximum admissible load capacities (see technical data).

17.3.2 Working with the Crocodile Gripper

To guarantee stability, make sure that the crocodile gripper is always kept near to the ground. Tip the upper part of the crocodile gripper hydraulically downward.

Different takes are possible with the crocodile gripper, such as: transport of silage fodder, loose hay, round bales, green fodder and farmyard manure, loading of towed vehicles and fertilizer spreader, mucking out of cow, pig and horse stables and many more.

The crocodile gripper is especially suited for the gripping of load material. In certain circumstances it can also be used to grip loose branches and smaller trunks or for feeding tasks.

17.3.3 Installing the Crocodile Gripper

See " Coupling of Tool Attachments " .

After having attached the crocodile gripper with the quick change system, the additional hydraulic connection must be connected.

17.3.4 Operation

Practice using the crocodile gripper before first application.

17.3.5 Operating Element

The crocodile gripper is operated with the operating lever for the additional hydraulic equipment (see operating instructions). When working with the crocodile gripper operate the lever with extreme care.

18 TOWNING

Never forget that towing may cause further damage to the vehicle .if possible, repair the vehicle on the spot.

If the engine is operative, the tool attachment is de-coupled. The operation depends on the actual condition of the vehicle and the hydraulic circuits.

Towing is only allowed with tow ropes of a sufficient diameter .the breaking strain of the ropes must be triple that of the traction power of the towing vehicle .the tow rope can be fixed at the support in the part of the vehicle or at the plate of the load arm.

18.1 Towing over longer distances

Only tow for a short distance that is necessary to bring the vehicle out of the danger area .never tow the vehicle longer distance as the hydraulic motors may be damaged .load the machine on an appropriate transporter.

18.2 Towing over shorter distances

Only tow at a slow driving speed (approx.5km/h) and for a maximum distance of 0.5km .only tow for a distance that is necessary to bring the vehicle out of danger areas. When towing over longer distances, the engine may overheat and become damaged.

18.2.1 ER1000

Move the throttle pedal into the desired direction .tow the vehicle.

18.2.2 ER1000

Safeguard the hydraulic system before towing.
For forward and rearward drive, remove the protective caps (if existing) from the valves. Loosen the nuts (Fig. 18-3 and 4) and turn threaded shanks (Fig. 18-1 and 2) until they are flush with the nuts.

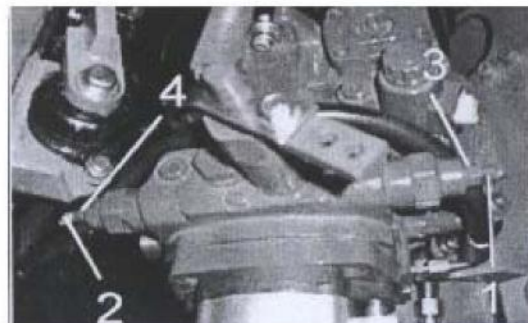

Fig.18



CAUTION !

DO NOT TURN THE THREADED SHANKS FURTHER THAN DESCRIBED ABOVE, AS IMPORTANT PARTS OF THE VALVED MAY BE DAMAGED.AFTER TOWING, TURN THE THREADED BOLTS (Fig. 18-1 AND 2) OUT UNTIL THEY STOP AND SECURE WITH THE COUNTER NUTS (Fig. 18-3 AND 4).

19 TRANSPORT AND LIFTING

19.1 transport

1. Before loading the vehicle on a transporter, remove any dirt.
2. For further instructions on parking the vehicle on the transporter please refer to the chapter “stopping and parking”. For transport, secure the vehicle correctly on the loading area. Lashing straps can be passed over the centre joint and the foot step. When handling by crane, lifting tackle is required.

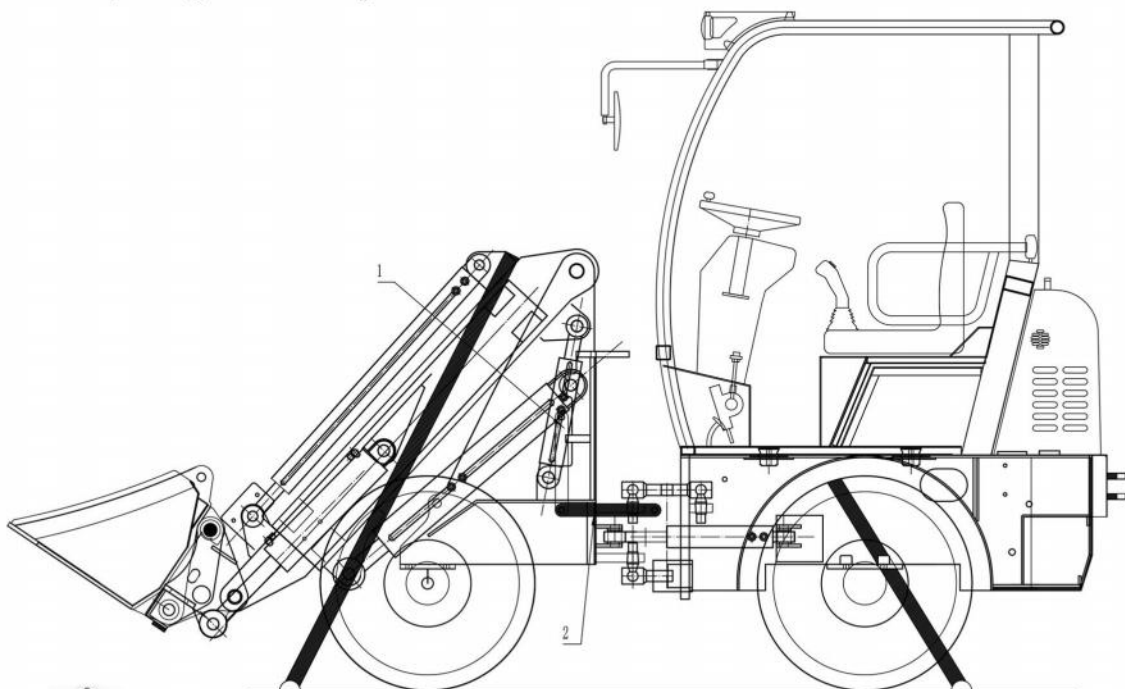

CAUTION!

BLOCK THE CENTRE-PIVOT STEERING.

3. Blocking the centre-pivot steering:
The vehicle must be parked straight.
Loosen the locking pins ((Fig.19.1-1) and move the lever to the rear.
Secure the lever with the locking pin (Fig.19.1-2) on the bolt provided therefore on the rear carriage.
4. To loosen the centre-pivot steering locking proceed in reverse order.

19.2 Lifting



As arrows shown in the picture above, these are lifting points.

Before lifting the whole loader, ensure the back lifting bolts is tightened and the lifting ropes can bear enough drawing force.

During lifting, ensure the whole loader is horizontal and pay attention to what is going on around the loader.

Don't move for longer distance during lifting the loader.

20 TECHNICAL DATA

20.1

ENGINE

- 3 cylinder perking diesel engine
- Cubic capacity: 1131cm³
- Power: 18.5kw(24.8 BHP) at 2800rpm

LOADER CAPACITY

- Operating weight: 2000kg
- Tipping load in shovel, vehicle straight,
Load arm horizontal: 800kg
- Tipping load in shovel, vehicle at angle 68°
Load arm horizontal: 498 kg
- Tipping load in pallet fork, vehicle straight,
Load arm horizontal: 600 kg
- Tipping load in pallet fork, vehicle at angle 68°
Load arm horizontal: 400 kg

Admissible load capacity

- On uneven ground: 60% of the tipping load, vehicle at angle 68°
- On even ground: 80% of the tipping load, vehicle at angle 68°

(The operating weight, lifting forces, the tipping load etc. will change depending on the ancillary equipment and tyres used)

Capacities please refer to table “capacities”, part C

- Hydraulic system incl. tank: 26.5L
- Diesel tank: 21L
- Engine oil: 4L
- Gear:
 - Rear axle: 1.5L
 - Front axle: 1.5L

Hydraulic system

- Working hydraulic
 - Flow rate: abt. 33l/min.
- Driving hydraulic
 - Flow rate: abt. 84l/min.
 - Working pressure: 305bar

Drive (driving speed):

- Gear: 0-12km/h

Electrical system:

- Operating voltage: 12 volt
- Battery: 60 Ah

Steering:

- Fully-hydraulic centre –pivot steering with double with action cylinder
- Rotating angle: $\pm 12^\circ$
- Steering hydraulic:
 - Flow rate: abt. 33l/min.
 - Working pressure: 190bar

Noise rating:

- ER1000 101dB(A)

The emission sound pressure level at the operator’s station is 88 dB(A).

The operator should be wear the earmuffs.

20.2 Dimensions

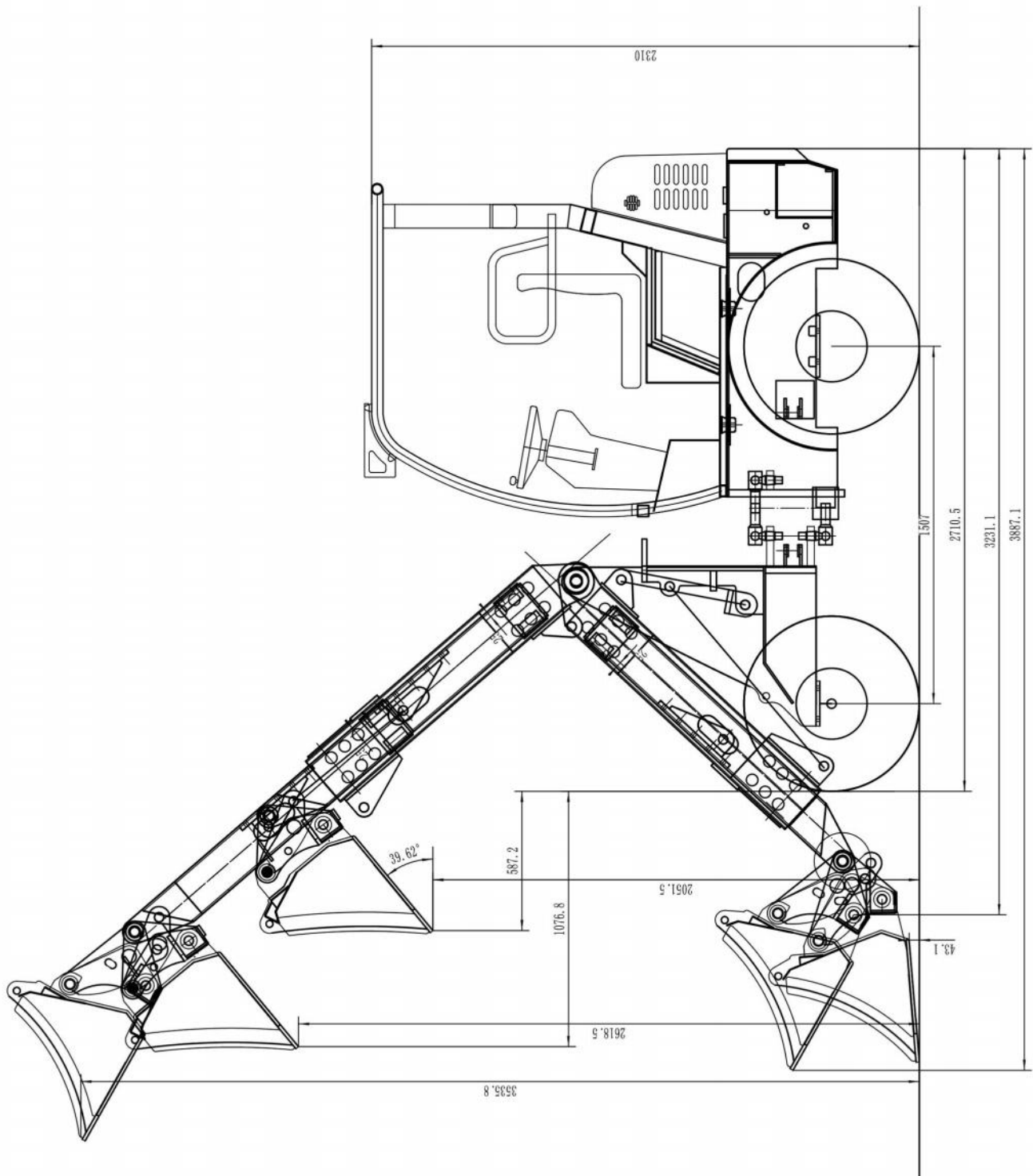

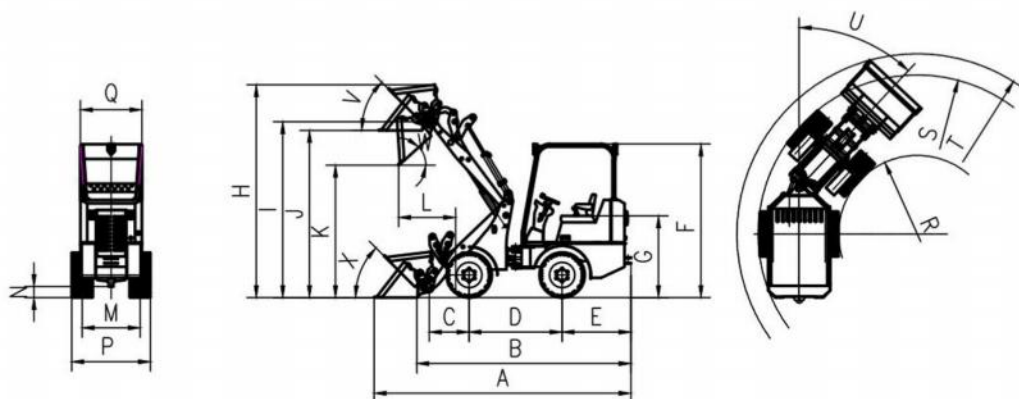

	Dimensions(mm)	standard
A	Total length with standard bucket	3887
B	Total length without bucket	3231
C	Axle center up to bucket hinge pin	520
D	Wheelbase	1507
E	Rear overhang	833
F	Height to top of ROPS bar	2310
G	Seat height	1255
H	Total working height	2959/3526
I	Max. height of bucket pivot	2741/3308
J	Overhead loading height	2523/3090
K	Max. dumping height	2051/2618
L	Operating distance for K	587/1076
M	Track width	760
N	Ground clearance	190
P	Total width	1180
Q	Bar width	1030
R	Inside turning radius	1500
S	Radius at the outer edge	2600
T	Max. turning radius	2900
U	Turning angle	40°
V	Rollback angle at max. lifting height	45°
W	Dumping angle	40°
X	Back-roll angle on the ground	35°

*Dimensions with standard tyres 27×8.5-15

Operating manual, part C

Maintenance / Trouble shooting



ER1000

These instructions belong with the vehicle

COTNENTS, PART C

21General	64
21.1Securing the Vehicle	64
21.2 Safety Support Of The Load Arm.....	64
21.3 general Safety Check.....	65
22Maintenance.....	65
22.1Maintenance Intervals.....	66
22.1.1Daily Maintenance.....	66
22.1.2Weekly Maintenance	67
22.1.3Inspection after 500operating Hours (Or After The First 6 Months).....	68
22.1.4further Maintenance Intervals.....	70
2.22 Maintenance of the Engine	73
22.2.1 Tilting the Driver’s Cabin	73
22.2.2 Changing the Engine Oil	74
22.2.3replacing the Engine Oil Filter	75
22.2.4 Checking the Oil Level of The Engine /Replenishment.....	75
22.3 Maintenance of the Fuel System	76
22.3.1fuel System	76
22.3.2water Separator	76
22.3.3 Replacing the Fuel Preliminary Filter	77
22.3.4 Replacing the Fuel Main Filter.....	77
22.3.5 Purging the Fuel System	77
22.4 Maintenance of The Air Intake	78
22.4.1 Removing Main Filter, Checking And Cleaning.....	78

22.4.2 Checking /Replacing the Safety Filter.....	78
22.5 Maintenance of the Cooling System.....	79
22.5.1 Checking the Antifreeze Mixture	79
22.5.2filling the Radiator.....	80
22.5.3cleaning the Cooling System	80
22.6 Maintenance of the Hydraulic System.....	81
22.6.1 Description of the Hydraulic System.....	81
22.6.2 Description of the Hydraulic System.....	81
22.6.3 Oil Cooler	82
22.6.4 Hydraulic Oil Level	82
22.6.5 Return Filter.....	83
22.6.6 Changing the Hydraulic Oil.....	83
22.6.7 Purge of the Working and Steering Hydraulic.....	84
22.7 Steering Mechanism	84
22.8 Maintenance Of The Axles	85
22.8.1 Checking the Level of the Gear Oil and Changing the Oil	85
22.9 Track Widening.....	85
22.10 ROPS	86
22.11 Cleaning the Vehicle	86
22.12 Safety Belt	86
22.13 Tyres and Wheels.....	87
22.13.1 Inflating the Tyres.....	87
22.13.2 Checking the Seat of the Wheels	87
22.14 Maintenance of The Brake System.....	88
22.14.1 Brakes	88
22.14.2 Brakes	88

22.14.3 Adjusting the Brakes.....	88
22.15 Electrical System	89
22.15.1 The Assignment Of The Fuses.....	89
22.15.2 Maintenance of the Electrical System	91
22.15.3 Battery	92
23 Trouble Shooting and Correction	93
24 Capacities and Fuel and Correction.....	97
24.1 Capacities.....	97
24.1.1 ER1000	97
24.2 Hydraulic Fluids (Mineral Oil Based).....	98
24.3 Environmentally Friendly Hydraulic Fluids.....	99
25 Lubrication Schedule.....	101
26 Tyre Pressure.....	103
27 Ordering Of Spare Parts	103

Service schedule

!To guarantee proper functioning of the machine, the first inspection is to be carried out after 30 operating hours, or three months after commissioning at the latest, by a *HAIYATE* dealer or a mechanic of a *HAIYATE* factory salesman. The proof of the inspection must be returned to the *HAIYATE* company as otherwise all warranty claims will be forfeited!

Work to be done (please mark (o))	1st service
Check gear-box, engine and hydraulic system for leaks	o
Check that hydraulic and engine oil cooler and radiator are clean	o
Check level of coolant and antifreeze	o
Check tension and condition of V-belt	o
Check the tubes and conduits for correct seat	o
Check position rods of the hydraulic cylinders	o
Tighten all screws check carefully the engine and axle mounts and the cardan shaft.	o
Check the instruments and the acoustic warning devices	o
Check the electrical system	o
Check the hydraulic steering	o
Check the lighting equipment(if fitted)	o
Check the idle speed RPM	o
Check and adjust, if necessary, the tappet clearance-only Perkins 1004-4engined	o
Check the locking function of the door and the engine cover	o
Check the tyre condition	o
Change motor oil and oil filter	o
Clean air filter and replace, if necessary	o
Replace hydraulic return filter	o
Check that all lubrication nipples are lubricated	o
Lubricate cardan shafts (universal joint)	o
Lubricate all levers, Bowden cables and hinges	o
Check all oil levels, including the oil levels of the gears and axles!	o

Observe the engine operating manual.

Place, Date

Signature/Stamp of the Dealer

Please complete and return the service schedule overleaf to:

GERT PIEPER GP TRADING

NIJKERKERSTRAAT 71 3882 PD PUTTRN NETHERLANDS

DETAILS ON THE VEHICLE /CUSTOMER

Type: _____ Chassis-No.: _____ Date of delivery: _____

Address of the customer

address of the dealer

Name: _____

Name: _____

Street: _____

Street: _____

Postal code & Town: _____ Postal code & Town: _____

Phone: _____ Phone: _____

Fax: _____ Fax: _____

Kind of use:

Agriculture/Farming

Building industry

community

Industry

Hire

others(.....)

MACHINE DATA

The nameplate on the right side of the front carriage near to the centre joint, contains the most important vehicle data .when ordering spare parts etc. this data should be entered in the following form:

GERT PIEPER GP TRADING

Model:vehicle-ident-No.:.....

Engine-type:..... Engine No.:.....

Date of delivery:..... Operating weight incl. shovel:.....

Importer (Name, Address):

Service workshop (name, address):

Space for additional notes:

21. GENERAL

21.1 securing the vehicle

Before any maintenance or repairs, the vehicle must be secured as described below:

1. Park the vehicle on even and load-carrying ground.
2. Put the tool attachments on to the ground.
3. Block the centre-pivot steering.
4. Shut off the engine.
5. Withdraw the key from the ignition switch.
6. Secure the vehicle against rolling away by blocking the wheels.
7. Disconnect the batteries before working on the electrical system or before welding

21.2 safety support of the load arm



CAUTION!

A LOAD ARM HAVING BEEN LIFTED CAN DROP SUDDENLY AND CAUSE SEVERE INJURIES.

BEFORE MAINTENANCE AND REPAIR, SECURE THE LOAD ARM WITH A SUITABLE SUPPORT.

21.3 General Safety Check

1. Check the steel parts for damage and note eventual damages of the enameling for subsequent repair.
2. make sure that all pivot pins are in their correct position and secured by the locking devices.
3. Check condition and correct position of the step and straps.
4. Check the windows for cracks and replace damaged windows.
5. Check condition and correct position of the shovel teeth.
6. Check all spreader disks for damage.
7. Check the tyres for damage and penetration of sharp-edged objects.
8. make sure that all warning signs are mounted. if necessary, attach new warning signs.

22 MAINTENANCE

Correct and regular maintenance is precondition for a consistent optimal vehicle performance.
Only Use HAIYATE Original Parts.

A vehicle that is not correctly maintained represents a danger for your employers.

Keep your vehicle in an operative and efficient condition through regular maintenance and lubrication. The service intervals are dependent on the operating hours and the daily work to be carried out. The operating time counter has to be regularly to define the maintenance intervals. When maintenance is due, the vehicle may not be used. Any malfunctions must be repaired immediately and carefully. The first service after 30operating hours should be carried out by a HAIYATE dealer or one of our representatives.



CAUTION!

MAINTENANCE SHOULD BE DONE BY PERSONS WHO HAVE RECEIVED AN APPROPRIATE TRAINING SECURE THE VEHICLE BEFORE STARTING MAINTENANCE .LOWER THE LOAD ARM AND PARK THE VEHICLE ON EVEN GROUND. SHOULD IT BECOME NECESSARY TO LIFT THE LOAD ARM RURING MAINTENANCE, THE SAFETY SUPPORTS MUST BE INSTALLED.

22.1 Maintenance Intervals

The intervals indicated refer to average operating conditions and loads .different maintenance intervals must be observed or in months, which ever comes first.

The intervals indicated are based on the quality of the operating materials specified in this manual.

22.1.1 Daily maintenance



CAUTION!

DAILY SERVICE (PERFORM DAILY OR AT LEAST EVERY 10 OPERATING HOURS)

- Clean the vehicle
- Clean the air filter
- Check for general damage
- Check the level and condition of coolant
- Check the hydraulic oil cooler, the radiator and the engine oil cooler for cleanliness
- Check the level and condition of the motor oil
- Check for engine leaks
- Check the level of the hydraulic oil
- Check the hydraulic system
- Check the condition of the tyres and the tyre pressure
- Check that all screws are tight.
- Check the wheel nuts
- Check the function of the brakes
- Check the safety belt
- Check the instruments and control lights as well as the acoustic warning devices
- Check the electric system
- Check the foot brake
- Check the hydraulic steering
- Check the function of the hydraulic devices
- Check the ancillary equipment
- Check the exhaust for defects or excessive smoke development
- Check the lubrication of all pivot pins
- Lubricate according to lubrication chart
- Lubricate the tool attachments
- Lubricate centre joint
- Lubricate pivot pin of steering cylinder
- Check that all screws of the ROPS structure are tight

22.1.2 WEEKLY MAINTENANCE

NOTE:

WHEN CHECK THE HYDRAULIC OIL LEVEL .THE VEHICLE MUST BE PARKED ON EVEN GROUND AND THE LOAD ARM BE LOWERED.



CAUTION!

WEEKLY SERVICE (PERFORM WEEKLY OR AT LEAST 30-50 OPERATING HOURS)

- Clean the fuel filter preliminary separator
- Check the front and rear axles for oil leaks and check the oil level
- Check the condition of the radiator and the tubes
- Check the tension and condition of the fan belt
- Check the ancillary equipment
- Check the piston rods of the hydraulic cylinders
- Check the position of pipes and tubes
- Check the air filter pipe
- Check the position of the electric cables
- Lubricate the cardan shafts (universal joint)
- Lubricates all levers
- Lubricate all Bowden cables and hinges
- Tighten all screws
- Check carefully the engine and axle mounts

22.1.3 INSPECTION AFTER 500 OPERATING HOURS (OR AFTER THE FIRST 6 MONTHS)

The inspection and maintenance personal must have adequate knowledge of the inspection and maintenance tasks to be carried out on this or comparable vehicles.

Maintenance(operating hours): <u>Or after the first twelve months at the latest</u> Maintenance work to be carried out:	500 hours
Check shift gear, engine and hydraulic system for leaks	×
Check that hydraulic and hydraulic oil cooler and radiator are clean	×
Check level of coolant and antifreeze	×
Check position of pipes and tubes	×
Check the piston rods of the hydraulic cylinders	×
Check the air filter pipe	×
Check the laying of the Bowden cables and the electric cables	×
Tighten all screws. Check carefully the engine and axle mounts and the cardan shafts.	×
Check the rubber buffer of the engine mount	×
Check the acid level of the battery	×
Check the instruments, control lights and acoustic warning devices	×
Check the electrical system	×
Check and adjust if necessary the foot brake and the parking brake	×
Check the hydraulic steering	×
Check the lighting equipment(if fitted)	×
Check the exhaust system	×
Check the drive shaft pivot pins and bushings	×

Maintenance(operating hours): Or after the first twelve months at the latest Maintenance work to be carried out:	500 hours
Check the bolts and the bearing of the centre joint	×
Check the idle speed RPM	×
Check and adjust the locking of the engine cover and the door, if necessary	×
Check the condition of the tyres and the tyre pressure	×
Check engine oil and replace filter	×
Replace fuel filter – clean preliminary filter	×
Clean or replace the air filter, if necessary	×
Adjust the tappet clearance (only Perkins 100 and 400 series)	×
Change hydraulic oil	×
Replace hydraulic return filter	×
Change the oil in the transfer gear-box	×
Change the oil in the axles	×
Check, that all lubrication nipples are lubricated	×
Lubricate cardan shafts	×
Lubricate all levers, Bowden cables, and hinges	×
Check all oil levels	×

NOTE

OBSERVE THE ENGINE OPERATING MANUAL.

22.1.4 Further Maintenance Intervals

The inspection and maintenance personal must have adequate knowledge of the inspection and maintenance tasks to be carried out on this or comparable vehicles.

Maintenance(operating hours)	Monthly At least Every 200-250 hours	Once per year at least every 1000 hours
Check shift gear ,engine and hydraulic system for leaks	×	×
Check that hydraulic cooler and radiator are clean	×	×
Check level of coolant and antifreeze	×	×
Check tension and condition of V-belt	×	×
Check position of pipes and tubes		×
Check the air filter pipe		×
Check the laying of the Bowden cables and the electric cables	×	×
Tighten all screws. check carefully the engine and axle mounts and the cardan shafts		×
Check the acid level of the battery	×	×
Clean the battery terminals and check the acid density	×	×
Check :the instruments ,control lights and acoustic warning devices	×	×
Check the electric system	×	×
Check and adjust if necessary the foot brake and the parking brake	×	×
Check the hydraulic steering	×	×
Check the lighting equipment (if fitted)	×	×
Check the exhaust system	×	×
Check the drive shaft pivot pins and bushings		×
Check the bolts and the bearing of the centre joint		×
Check the pressure control valves of the hydraulic system		×
Check the idle speed RPM	×	×
Check the RPM under max. load/without load		×
Check the starter and the generator (refer to engine manual)		×
Check the heater plugs and the injection nozzles (see engine operating manual)		×
Check and adjust the tappet clearance, if necessary		×
Tighten the cylinder head studs(only Perkins 100 series)		×
		×

Maintenance : (operating hours)	Monthly at least every 200-250 hours	Once per year at least every 1000 hours
Check and adjust the locking of the engines cover, if necessary	×	×
Check the ROPS bar/cabin		×
Check the condition of the tyres and the tyre pressure	×	×
Change the engine oil and the oil filter(Perkins 100 series, every 100 operating hours (1))	×	×
Replace fuel filter-clean preliminary filter		×
Clean or replace the air filter ,if necessary	×	×
Change hydraulic oil		×
Replace hydraulic return filter		×
Pressure filter (1 st change after 500 operating hours, following changes as required)		
Change the oil in the transfer gear-box		×
Change the oil in the axles		×
Change the coolant –every 2 years		×
Check ,that all lubrication nipples are lubricated	×	×
Lubricate all cardan shafts(universal joint and sliding joint)	×	×
Lubricated all levers, Bowden cables, and hinges	×	×
Check all oil levels	×	
Inspect according to the rules for the prevention of accidents		×

(1) The interval can be increased to 200 operating hours, if the operating hours exceed 30 hours per week and a high –quality mineral oil (specification CF OR CG) is used.

NOTE

OBSERVE THE ENGINE OPERATING MANUAL.

Tappet clearance Perkins engine, 100 series: inlet and outlet 0.2mm with cold engine

Tappet clearance Perkins engine, 1000series: inlet 0.2mm and outlet 0.45 mm with cold engine

Please enter the regular inspection below:

At operating hours

1st inspection carried out on: _____

Operating hours: _____

Stamp/ signature: _____

At operating hours

2nd inspection carried out on: _____

Operating hours: _____

Stamp/ signature: _____

At operating hours

3rd inspection carried out on: _____

Operating hours: _____

Stamp/ signature: _____

At operating hours

4th inspection carried out on: _____

Operating hours: _____

Stamp/ signature: _____

At operating hours

5th inspection carried out on: _____

Operating hours: _____

Stamp/ signature: _____

22.2 Maintenance of the engine

Service and maintenance the engine as specified in the operating and the engine manual .observe especially the service schedule.

22.2.1 Tilting the driver's cabin



CAUTION!

THE ENGINE COVER MUST NOT BE OPENED WHEN THE ENGINE IS RUNNING.

1. If necessary, the driver's seat must be slightly pushed forward.
2. Depress the lever (fig.-A) to unlock the locking of the driver's seat.
3. At the same time take the driver's seat by the lever (fig-B) and tilt it upwards.
4. When the driver's seat is completely tilted, it is secured by the rope(fig.-C).

Closing is done in reverse order.



ATTENTION!

WHEN YOU TILT THE DRIVER'S SEAT BACK, MAKE SURE THAT LOCKING ENGINES CORRECTLY

22.2.2 Changing the engine oil



Caution! Danger of scalding through hot engine oil!

Collect the waste oil and dispose of it in an environmentally friendly way.

1. Run the engine until it reaches operating temperature.
2. Park the vehicle on even ground and secure against rolling away.
3. Stop the engine.
4. Put a collecting container under the opening .the capacity of the container required is determined in the capacity chart in this operating manual.
5. Unscrew the cap and drain the engine oil .
6. After the engine oil has been drained off.
 - Replace the engine oil filter.
 - Mount the cap in the oil sump and tighten the screw with the correct torque of Perkins=30...40 Nm.
 - Replenish the engine oil through the filler neck until the oil level has reached the “max” mark.
 - Start the engine and run at idle speed for approx.2 minutes.
 - Check the oil level and replenish the oil –if necessary –to the “max” mark.
 - Check the engine for leaks.

22.2.3 Replacing the Engine Oil Filter

The engine is equipped with a screw type filter. Remove the cap behind the left rear wheel. Before unscrewing the filter case (with a tightening strap) position a collecting container to collect the drained off oil. Remove the old filter element and clean the filter case. Fill the new filter element with oil and insert the filter element in the filter case. Before screwing on the filter case, moisten the sealing surface with oil. Screw the filter on by hand (without the tightening strap).



NOTE:

THE FILTER CARTRIDGE IS EQUIPPED WITH A BY-PASS VALVE WHICH OPENS WHEN THE FILTER CLOGGED.

22.2.4 Checking the oil level of the engine /replenishment

1. Park the vehicle on even ground and secure against rolling away.
2. Stop the engine.
3. Draw out the oil-level gauge (Fig.-1) after one minute.
4. Wipe off the oil level gauge with a clean lint-free cloth and put it in again.
5. Draw out the oil level gauge, the oil level should be within the marks. If the oil level is only slightly above the “min.” mark, replenish oil through the filler neck (Fig.-2).



CAUTION!

THE OIL LEVEL MAY NOT DROP BELOW THE “MIN” MARK.

22.3 Maintenance of the fuel system

22.3.1 Fuel system

From the tank the fuel flows through a sieve with water separator (fig.1) and a filter (fig.2) and is pumped by an electric pump through a second filter to the injection pump.

All filters and sieves must be cleaned at regular intervals.

22.3.2 Water separator

The water separator is located besides the front left engine bearing.

When the red plastic ring floats in the viewing glass of the water separator, the water that has collected in the viewing glass must be drained off.

1. Close the stop valve at the water separator (lever in horizontal position).
2. Loosen the ferrule nut.
3. Take off and clean the viewing glass.
4. Replace the filter cartridge.
5. Install the viewing glass with ferrule nut.
6. Open the stop valve (lever in vertical position).



22.3.3 Replacing the Fuel Preliminary Filter

The fuel preliminary filter can only be replaced together with the housing.

22.3.4 Replacing the Fuel Main Filter

1. Open the seat base cover.
2. Loosen and unscrew the filter cartridge (fig.-1) with standard tools. Collect any leaking fuel.
3. Clean the sealing surface of the filter support (fig.-2) from any dirt that might have collected. Lightly oil the rubber seal (fig.-3) of the new filter cartridge or moisten with diesel fuel.
4. Screw on the filter cartridge manually until the seal is correctly seated. Tighten the filter with a further 1/2 turn .check for tightness.

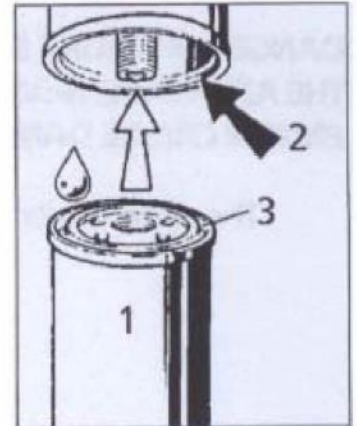

22.3.5 Purging the fuel system

- Replenish the fuel tank completely.
- Move the ignition key to position 1(operation).
- Wait for a minute. The system is purged automatically.



CAUTION!

COLLECT THE BLED OFF FUEL AND DISPOSE OF IT IN AN ENVIRONMENTALLY FRIENDLY WAY.

22.4 Maintenance of the air intake.

For having access to the air intake open the engine cover and tilt the seat base cover.



WARNING!

DANGER OF INJURY BY ENGINE PARTS !STOP ENGINE BEFORE STARTING WORK NEAR THE AIR INTAKE .NEVER START THE ENGINE WITH PARTS OF THE AIR INTAKE REMOVED .THE ENGINE CAN BE DAMAGED,WHEN THE ENGINE TAKES IN UNCLEAN AIR.

The wheel loader is equipped with a dry-type filter consisting of a main filter and a safety filter.

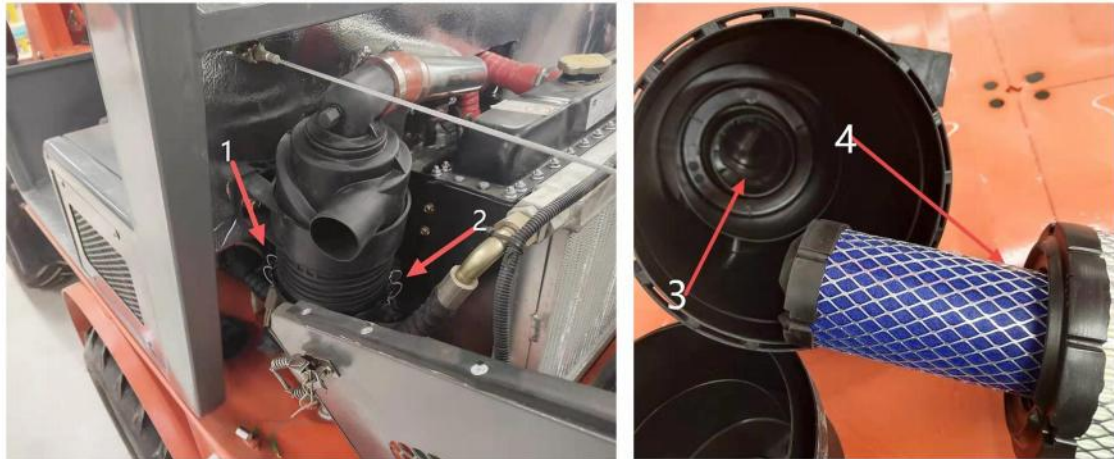

22.4.1 Removing main filter, checking and cleaning

1. Loosen spring-clips (fig.-1), remove the cap (fig.-2).
2. Pull out the main filter element (fig.-3).the safety filter (fig.-4) is not removed.
3. Clean or replace the filter cartridge.
4. The new or the cleaned filter element is installed in reverse order. Replace the filter, when the filter paper or the seal is damaged.
5. Check the intake pipe between the filter and the engine for security of attachment and correct sit. The exterior of the intake pipe may not be damaged. The exterior of the hose coupling between the filter and the intake pipe may not be damaged.

22.4.2 Checking /replacing the safety filter

Replace the safety filter (fig.-4) if required but after cleaning of the main filter at the latest. When, during service work of the dry-type filter, a maintenance error or a damaged main filter becomes evident, the safety filter must be replaced.

22.5 Maintenance of the cooling system

The oil cooler is mounted behind the diesel engine.

it is accessible when you tilt the tailgate.

To do so, unscrew the two ring nuts (fig.-1).

If the hydraulic system feels too hot during longer road journey or high ambient temperatures, check that the cooler is clean and the V-belt for the fan is correctly tensioned.



The level of the coolant must be checked at regular intervals. When you look into the radiator opening from above, the radiator ribs must be covered with coolant. When coolant must be topped up, make sure that enough antifreeze has been added. The antifreeze prevents the coolant from freezing at low temperatures and protects the engine block and the radiator from internal corrosion

22.5.1 Checking the antifreeze mixture

The antifreeze prevents freezing of the coolant at the temperatures below 0° and protects the engine unit and the radiator from internal corrosion .under normal conditions antifreeze content between 20 and -30°C is sufficient. The antifreeze content can be determined with a standard measurement tool.

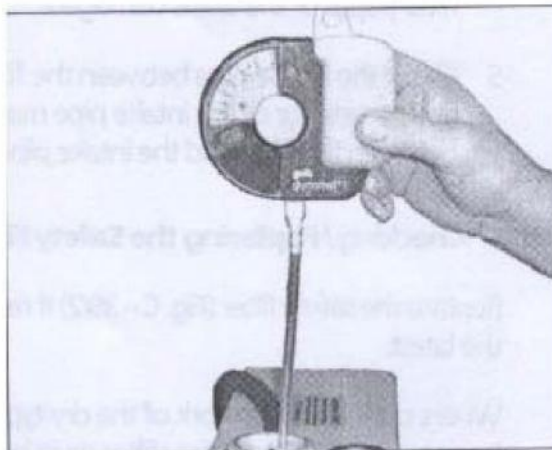

22.5.2 Filling the radiator



CAUTION!

DANGER OF BURNING THROUGH HOT COOLANT—NEVER OPEN THE RADIATOR SYSTEM WHEN THE ENGINE IS HOT OR THE SYSTEM IS UNDER PRESSURE.

The coolant should consist of equal quantities of water and antifreeze to guarantee an optimum relationship between cooling capacity and protection from corrosion.

When the coolant is filled in (if the total quantity has to be filled in, for example when the coolant is changed), do not top up too quickly (**maximum 5 L/min!**), in order to prevent the inclusion of air bubbles in the system which may result in an overheating of the engine.



22.5.3 Cleaning the Cooling System

When the control light “2” at the instrument panel lights up, switch off the engine immediately. To determine whether engine or hydraulic oil (or both) have got overheated, disconnect the cable at one of the temperature indicators.

The higher the dust contents in the air the more often the cooling systems need to be checked.

When you hold a portable light behind one of the coolers you must be able to see light through all of the openings.

Clean the cooler with compressed air. If the cooler is highly contaminated use water under high pressure to remove the dirt collected. Make sure not to bend the cooler ribs. Ribs that have been bent must be straightened.

- Clean the engine cooler
- Clean the hydraulic oil cooler
- Clean the generator with compressed air

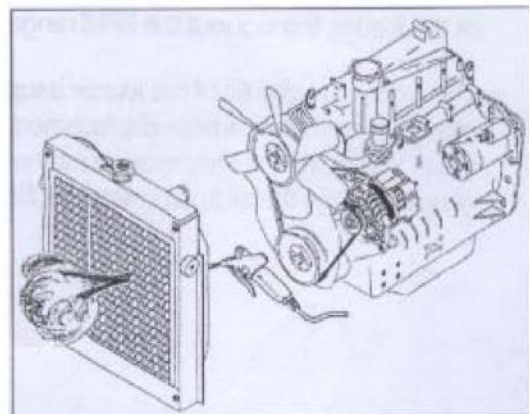

22.6 Maintenance of the Hydraulic System

22.6.1 Description of the Hydraulic System (ER1000)



CAUTION!

MAKE SURE THAT MAINTENANCE WORK IS DONE WITH EXTREME CLEANLINESS. DIRT OR WATER IN THE OIL MAY CAUSE PREMATURE WEAR OR COMPLETE FAILURE OF THE COMPLETE SYSTEM. ONLY USE AN APPROPRIATE HYDRAULIC OIL (SELECTION CHART) OUT OF CLOSED CONTAINERS. BEFORE INSTALLATION, CLEAN THE INSIDE OF THE HYDRAULIC TUBES.

A hydraulic tandem gear pump is flange-mounted on to the diesel engine. The rear pump is controlled by the foot valve and supplies pressure to the drive. The system is protected from overpressure by the pressure control valve. When the foot valve is not operated, the oil returns without pressure to the oil tank.

The front pump supplies the steering and the lifting hydraulic. The oil flow to the hydraulic cylinders of the load arm or to the front hydraulic connection is controlled via the four-way control valve. The oil can also be supplied to the drive circuit by operating an additional lever (hydraulic overdrive). The oil return flow to the tank passes a return filter. The capacity of the hydraulic oil tank is indicated in the capacity chart. The oil temperature may not exceed 80°C. The oil level can be read on the oil level gauge.

22.6.2 Description of the Hydraulic System (ER1000)

A hydraulic variable displacement pump is flange-mounted on to the diesel engine. The displacement is automatic and infinitely variable, but speed and load controlled. The speed of the vehicle is determined by the RPM of the engine and the load. Forward drive is effected by depressing the accelerator pedal, the maximum speed is limited by the max. RPM of the engine.

Depending on the load of the loader, the variable displacement pump is automatically adjusted to maintain optimum engine torque. The greater the vehicle load (e.g. during loading or driving uphill), the lower the driving speed. This ensures that maximum efficiency is obtained throughout the complete performance range. The displacement can be further influenced by depressing the inch pedal (the pedal on the left side looking in the drive-direction) to achieve a gradual throttling of the loader, throughout the RPM range, until the vehicle has stopped.

The working hydraulic of the loader is supplied by a hydraulic gear pump. The pump is flange-mounted on to the variable displacement pump and supplies the steering and the control valve of the load arm. The oil temperature may not exceed 80°C. The oil level can be read on the oil level gauge. Change the oil and replace the filter in accordance with the inspection schedule.

22.6.3 Oil Cooler

The oil cooler is mounted on the front carriage for the load arm. The electric fan is switched on via a thermal switch which is incorporated in the variable displacement pump, when the oil temperature has reached 55°C the switch turns the fan on.

If the hydraulic system gets too hot during longer road journeys or high ambient temperatures, check that the cooler is clean



22.6.4 Hydraulic Oil Level



CAUTION!

PARK THE WHEEL LOADER ON AN EVEN SURFACE AND LOWER THE TOOL ATTACHMENTS ON TO THE GROUND. APPLY THE PARKING BRAKE. STOP THE ENGINE. OPERATE THE CONTROL LEVERS FOR THE TOOL ATTACHMENTS UNTIL ALL WORKING MOVEMENTS OF THE TOOL ATTACHMENTS ARE STOPPED TO RELEASE PRESSURE FROM THE HYDRAULIC SYSTEM.

SECURE THE VEHICLE AS DESCRIBED IN CHAPTER "PARKING THE VEHICLE".



CAUTION!

THE HYDRAULIC TANK CAN BE UNDER SLIGHT PRESSURE.

1. To check the hydraulic oil level, loosen the cap (Fig.-2) by one turn and close again immediately (pressure escapes).
2. The oil level should be in the upper range of the centre of the oil pointer (Fig.-1)
3. If the oil level is low, loosen the purge filter (Fig.-2) and replenish the hydraulic oil through the Opening until the oil level has exceeded the centre of the oil pointer. Screw in the purge filter again.



22.6.5 Return Filter

The hydraulic system is equipped with one return filter (Fig.-3). An incorporated by-pass valve protects the return filter from excess pressure. When the by-pass valve is open, the filter is not efficient. Therefore, you must replace the filter cartridge as soon as possible.

1. Unscrew the cover(Fig.-1).Remove the filter cartridge(Fig.-3).
2. Install the new filter cartridge
3. Check the seal(Fig.-2).Replace the seal, if damaged.
4. Screw on the cover.

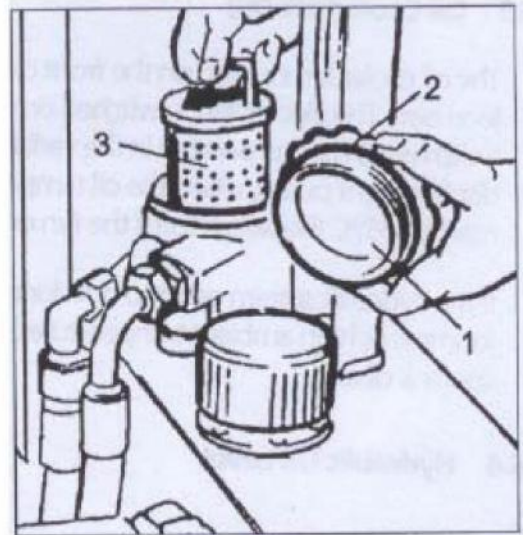

22.6.6 Changing the Hydraulic Oil



CAUTION!

DANGER OF SCALDING BY HOT HYDRAULIC OIL COLLECT THE HYDRAULIC OIL FLOWING OUT AND DISPOSE OF IT IN AN ENVIRONMENTALLY FRIENDLY WAY. READ AND OBSERVE "INSPECTION, MAINTENANCE, SAFETY". NEVER START THE ENGINE WHEN THE HYDRAULIC TANK IS EMPTY. SECURE THE VEHICLE FROM UNAUTHORISED USE.

1. Lower the tool attachments on to the ground.
2. Stop the engine and apply the parking brake.
3. Put a container under the hydraulic tank. The capacity required is indicated in the capacity chart.
4. Loosen the purge filter.
5. Unscrew the drain plug at the bottom of the hydraulic tank.
6. Unscrew the cover (Fig.-1).Clean the bottom of the tank and the inner surfaces with hydraulic oil or scavenge oil. Screw on drain plug.
7. Replenish hydraulic oil through the sieve below the purge filter until the upper mark of the oil level gauge. Screw on the purge filter and purge the complete system.

22.6.7 Purge of the Working and Steering Hydraulic

The hydraulic system must be purged after each hydraulic oil change, longer periods of non use or malfunctions of the hydraulic system.

Working Hydraulic

1. Check the oil level of the hydraulic tank and replenish if required.
2. Start the engine and run at idle speed for several minutes. Retract and extend the piston rods of all hydraulic cylinders several times.

Steering Hydraulic

1. Turn the steering wheel to the full extent in both directions while the engine is running.
2. Repeat the procedure until the steering can be operated perfectly without and noise.
3. After purging check the hydraulic oil level again and replenish oil, if necessary.

22.7 Steering Mechanism

The vehicle is equipped with a centre-pivot steering combined with a self-aligning beating that ensures that all four wheels make contact with the ground at all times. The centre joint must be lubricated daily with multipurpose grease.

22.8 Maintenance of the axles



CAUTION!

PARK THE VEHICLE ON EVEN GROUND AND LOWER THE TOOL ATTACHMENTS ON TO THE GROUND. STOP THE ENGINE AND APPLY THE PARKING BRAKE SECURE THE VEHICLE(SEE CHAPTE "PARKING"). DANGER OF SCALDING BY HOT OIL COLLECT THE OIL FLOWING OUT AND DISPOSE OF IT IN AN ENVIRONMENTALLY FRIENDLY WAY.

Serve the axles according to the service schedule.

22.8.1 Checking the Level of the Gear Oil and Changing the Oil

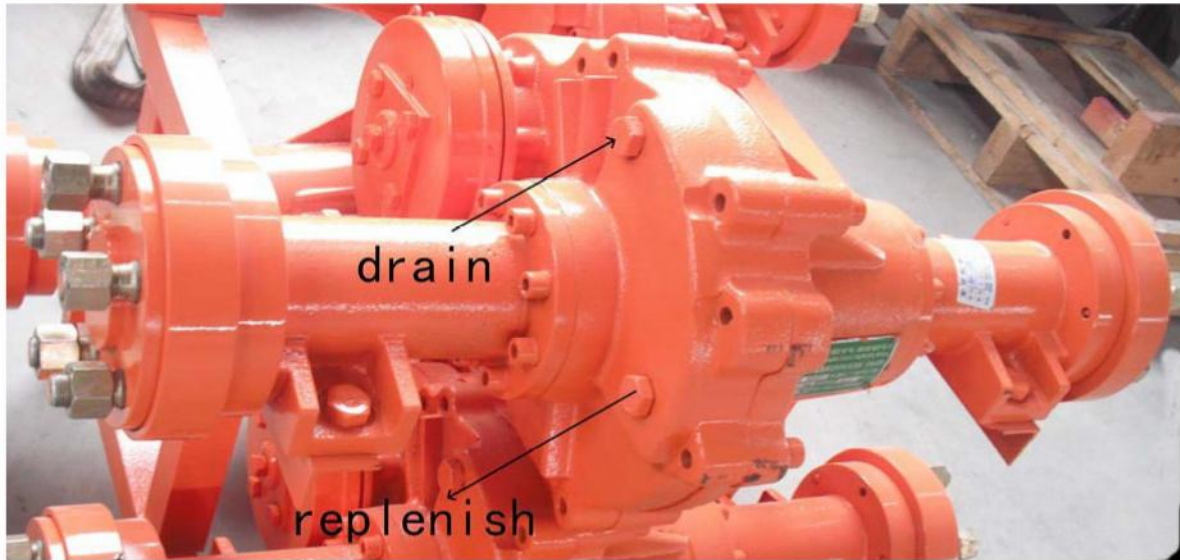

1. Screw out the hexagon socket (at the side of the casing). The oil level should reach the bottom edge of the threaded boring.
2. Screw out the hexagon socket at the right bottom of the differential casing cover.
3. Drain off and collect the oil.
4. Mount the hexagon socket with sealing agent.
5. Replenish oil until the oil level has reached the upper edge of the boring.
6. Mount the filling neck.

22.9 Track Widening

A track widening or equipping with twin tyres must be approved by the manufacturer.

22.10 ROPS

The vehicle is equipped with a roll-over protective structure(ROPS).Working with a ROPS that is not fitted or faulty may cause fatal accidents or serious injuries. A changed or improperly repaired ROPS is dangerous. When the ROPS has been damaged by an accident, the vehicle may only be used after repair and check of the ROPS by a qualified person.

Contact your HAIYATE dealer or one of our representatives. Ignorance of these instructions may cause fatal accidents or serious injuries.

1. Check the ROPS for damages.
2. Make sure that all screws are tight.
3. Check the torque of the screws. If necessary, torque screws.

IF THE ROPS IS TO BE REMOVED, SPECIAL INSTRUCTIONS HAVE TO BE OBSERVED.

22.11 Cleaning the Vehicle

As long as the vehicle is new (first three months) it should only be cleaned with a sponge, As the coating has not hardened completely, cleaning with a water jet may cause damage to the finish.

When you clean the vehicle, pay particular attention to the underside. No mud may collect at the engine and the gear-box. Make sure that the radiator grid is not dogged. The vehicle is splash-proof. Do not clean the dashboard, the generator, the compact connector or the radiator with a sharp water jet (high-pressure cleaner). Cover the multifunction-lever before cleaning.



CAUTION!

BEFORE CLEANING THE ENGINE, THE ALR FILTER SOCKET MUST BE COVERED.

22.12 Safety Belt

The safety belt must be replaced when it is damaged, worn or after an accident. Beyond that the safety belt should be renewed every three years.

Check the safety belt for fraying and elongation. Make sure that the seams are not damaged and check the function of the lock.

Make sure that the screws are fitted correctly and are tight.

22.13 Tyres and Wheels



CAUTION!

INFLATED TYRES CAN GET VERY HOT ,EXPLODE AND CAUSE FATAL ACCIDENTS. DO NOT CUT OR WELD THE WHEEL RIMS. REPAIRS SHOULD BE DONE BY A TYRE OR WHEEL SPECIALIST.

22.13.1 Inflating the Tyres

The following instructions refer to the inflation of the tyres after a drop in pressure. After a complete drop in tyre pressure, this task should be undertaken by a trained tyre mechanic with appropriate equipment.

1. Preparing the Wheel:
Check that the tyre is correctly seated.
2. Preparing the Equipment
Use only a pressure supply with a pressure regulator. Adjust the regulator to max.1.38 bar above the recommended tyre pressure. Use an air hose with self-locking pneumatic chuck and remote stop valve.
3. Inflation:
Make sure that the air hose is fitted correctly to the tyre valve .Keep persons away. When inflating, stand to the rear of the tyre and inflate until the recommended pressure has been reached (see air pressure table).

22.13.2 Checking the Seat of the Wheels

When the vehicle is new, or, after having replaced one wheel, check the torque of wheel nuts every two hours until the value does not change. Make sure every day before vehicle use that the wheel nuts are tight.

The correct torques is indicated in the chart below:

	Front Wheels	Rear Wheels
Wheel nuts M18×1.5	310 ± 45Nm	310 ± 45Nm



CAUTION!

WHEN REPLACING A WHEEL BOLT, ALL BOLTS OF THE CORRESPONDING WHEEL MUST BE RENEWED, AS THE OTHER BOLTS MAY ALSO BE DAMAGED.

22.14 Maintenance of the brake system

Damaged brakes can cause fatal accidents. Therefore, have your brake system checked regularly by your dealer. During service, check the function of the brake system and adjust the brakes if necessary. Only continue to work with the vehicle after the fault has been corrected.

22.14.1 Brakes

The vehicle is equipped with a foot brake and a parking brake. The brake system consists of a drum brake located on the differential at the input to the rear axle. It is operated via Bowden cables of the parking brake lever or the foot brake pedal. Although the brake drum is fitted to the rearward axle, it has a mechanical effect on all four wheels via the drive.

22.14.2 Brakes

The hydrostatic drive is used as service brake. The vehicle service brake is operated via the Inch brake pedal which acts on all four wheels by removing pressure from the hydraulic drive. The loader is also equipped with a foot brake and a parking brake. The brake system consists of a drum brake on the differential at the input to the rear axle. It is operated via Bowden cables of the parking brake lever or the foot brake pedal. Although the brake drum is only fitted to one axle, it has a mechanical effect on all four wheels via the drive.

22.14.3 Adjusting the brakes

When adjusting the brakes, check that the brake drum can rotate freely. The brake pedal, however, must not be depressed until stop. When the brake is released you must be able to press the brake lever at the brake drum upwards by about 5 mm. The brakes are adjusted with the nuts (Fig.-1).

The parking brake cable can also be regulated at the setting screw of the parking brake lever. Release the brake to stretch the cable and turn the setting screw carefully to the left. Take care not to exceed a torque of 7Nm.

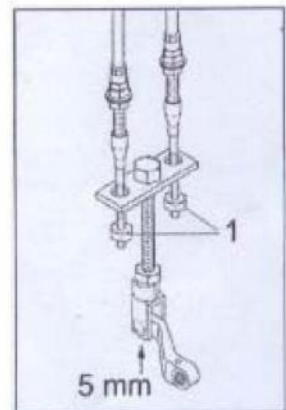

22.15 Electrical System

The electrical system has a nominal voltage of 12 Volts and is supplied by an alternator.

The battery capacity is 66 Ah. The battery is located in the tail of the vehicle and becomes accessible when the tailgate is tilted. To do so, unscrew the two ring nuts (fig.-1).

The electrical consumers and their supply lines are protected by fuses which are mounted in the fuse boxes on the right-hand side of the steering column.



22.15.1 The assignment of the fuses

Vehicles with lighting equipment

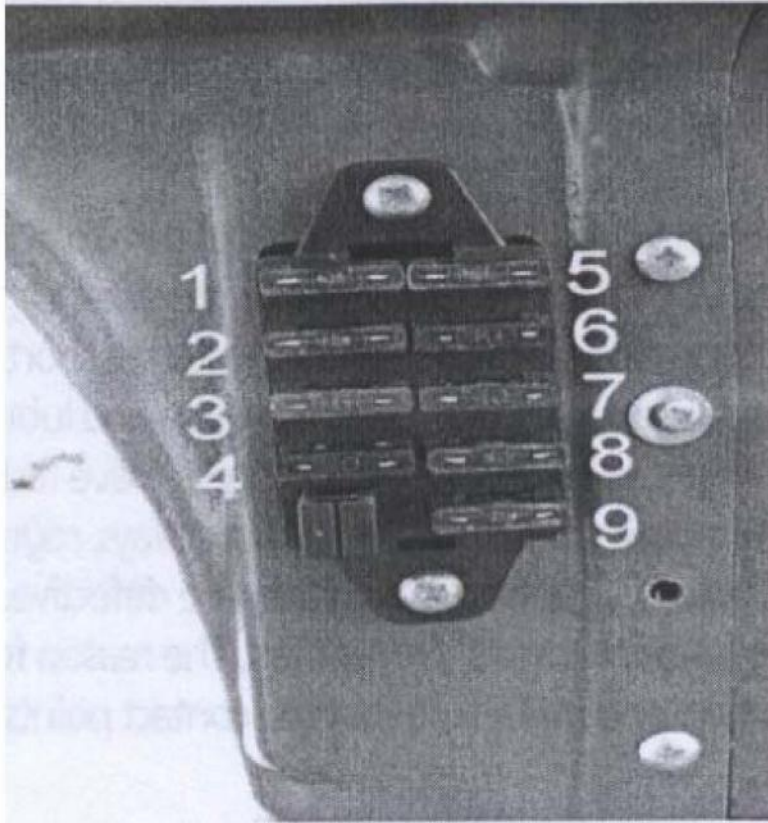

Box 1		
Item	Protected function	Capacity (A)
1	ignition	15
2	working lights	15
3	preheat protection	5
4	fan	10
5	generator	15
6	stop switch	10
7	sucking diesel oil	10
8	forward backward	15
9	horn meter	15

22.15.2 Maintenance of the Electrical system

The vehicle is splash-proof. Do not clean the dashboard, the generator, or the compact connector with a sharp water jet (high-pressure cleaner).

The electrical system must be serviced as necessary. Make sure to avoid short circuits when you are working on the electrical system. First disconnect the battery starting with the negative pole or operate the battery disconnecting switch. To avoid an internal short circuit do not place any tools on the battery. Keep the pole ends and the terminals clean and lubricate with slushing grease. Do not touch bulbs and headlight reflectors with your fingers. Have faults at the starter and the generator repaired by your dealer. Small devices, such as relays, regulators, the ignition switch, direction indicators etc should be replaced when they are defective. Make sure that the connecting lines and the fuses are correctly connected. The reason for blown fuses is normally a short circuit, Check the cables and make sure that the contact points of the fuses are insulated.

CAUTION!

To avoid damage to the electrical system observe the following instructions:

1. When welding, connect the ground terminal of the welding device directly with the part to be welded. The generator must be disconnected. Remove the battery before starting welding.
2. Electrical lines must not be disconnected when the engine is running
3. Do not bridge fuses and the preheating controller. Replace defective parts by original parts of the same size.

22.15.3 Battery

Batteries give off gases that can explode. Do not smoke and keep the battery away from sparks and flames.

Battery electrolyte contains sulphuric acid which can irritate skin and eyes. Wear protective glasses. Be careful not to spill the acid. Keep metal parts away from the terminals to avoid short circuits and burnings,

Before disconnecting the battery and reconnecting it, set all switches in the driver's cabin and the battery disconnecting switch to "Off" . The earth cable(-) must be disconnected first.

When connecting the battery, first connect the positive (+) cable.

Charge the battery at some distance from the machine in a well ventilated area. Switch off the charge circuit before disconnecting or connecting the battery. After installation, wait for five minutes before connecting the battery.

The exterior of the casing is marked with "Min/Max" marks. The electrolyte level should be within these marks and be visible through the battery casing. If this is not true, remove the battery plug and check the electrolyte level from above (10 mm above the battery plates). Replenish distilled water, if necessary.

Failure/Trouble	Possible Cause	Correction
Engine does not start off	Fuel tank empty.	Refill fuel tank and purge the fuel System, if necessary.
	Fuel filter clogged, paraffin sedimentation in winter.	Replace the fuel filter, use fuel for cold temperatures.
	Fuel solenoid not released.	Check the fuses.
	Leaky fuel pipe.	Tighten all screws and clamps.
	Starting RPM too low.	Check and charge battery, check fit of battery terminals.
Vehicle does not drive while engine running.	Parking brake applied.	Release parking brake.
	Parking brake switch damaged.	Replace parking brake switch.
	Inch cartridge not in O position.	Check the Bowden cable and return spring, replace if necessary.
	Drive pump solenoid supply failure	Check fuses. Have the multifunction-lever and the electronic system checked by the workshop.
Engine gets too hot.	Radiator/oil cooler is dirty.	Clean.
	Coolant level too low.	Replenish coolant.
	Thermostat jammed.	Have thermostat replaced by the Workshop.
	V-belt loose	Tension V-belt.
	Oil level too high or too low.	Correct oil level.

Failure/Trouble	Possible Cause	Correction
Hydraulic system gets too hot	Hydraulic oil cooler dirty.	Clean
	Hydraulic oil level too low.	Replenish hydraulic oil.
	Load too high.	Reduce load of the vehicle, stop working.
Degraded vehicle performance.	Air filter dirty Fuel filter dirty	Replace.
	Incorrect fuel type.	Change fuel type.
	Inch pedal jammed.	Check and repair.
	Engine RPM too low.	Adjust RPM.

Observe the engine operating manual!

TROUBLE SHOOTING-PUMP / ENGINE

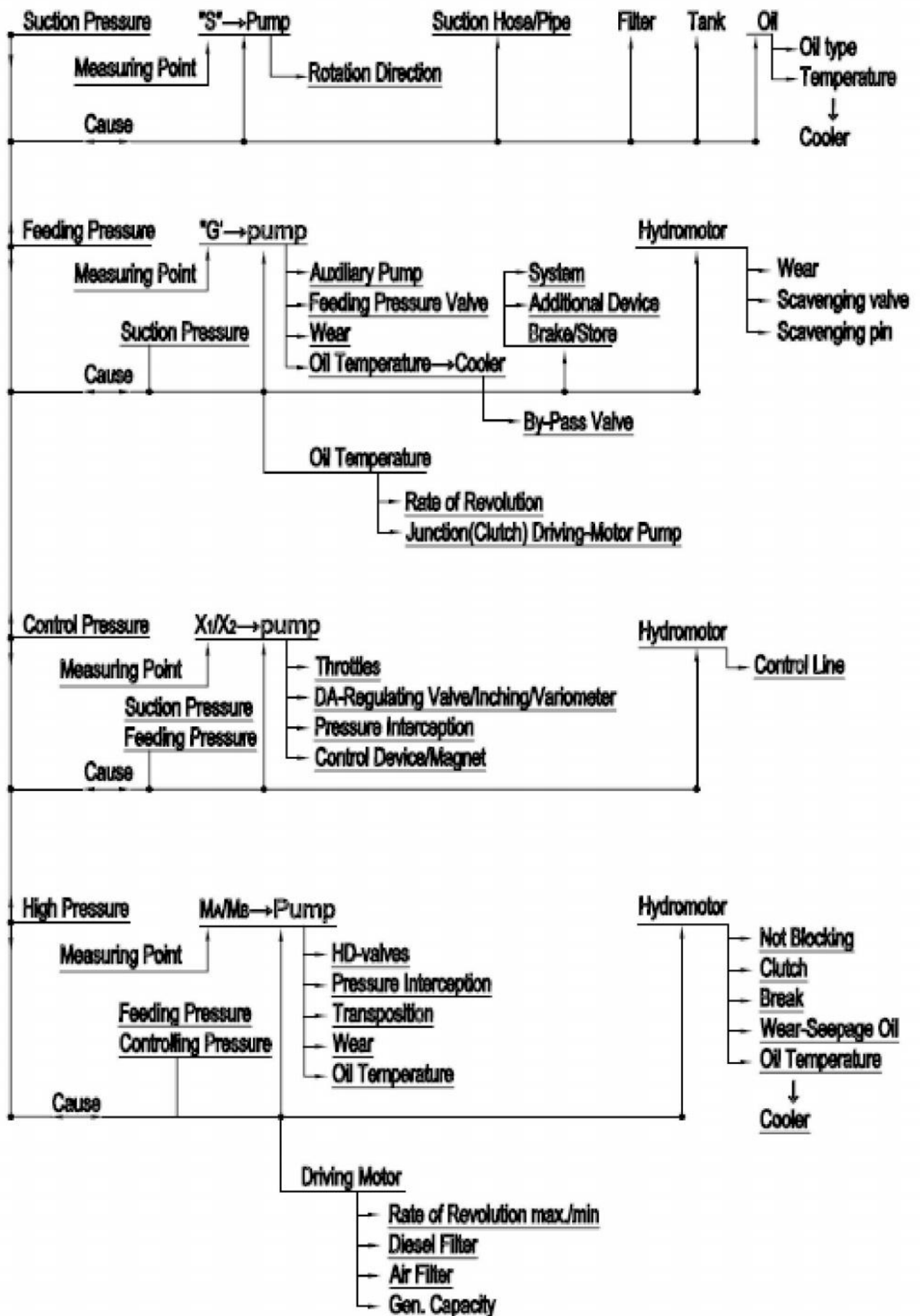

TRUBLE SHOOTING-VEHICLE

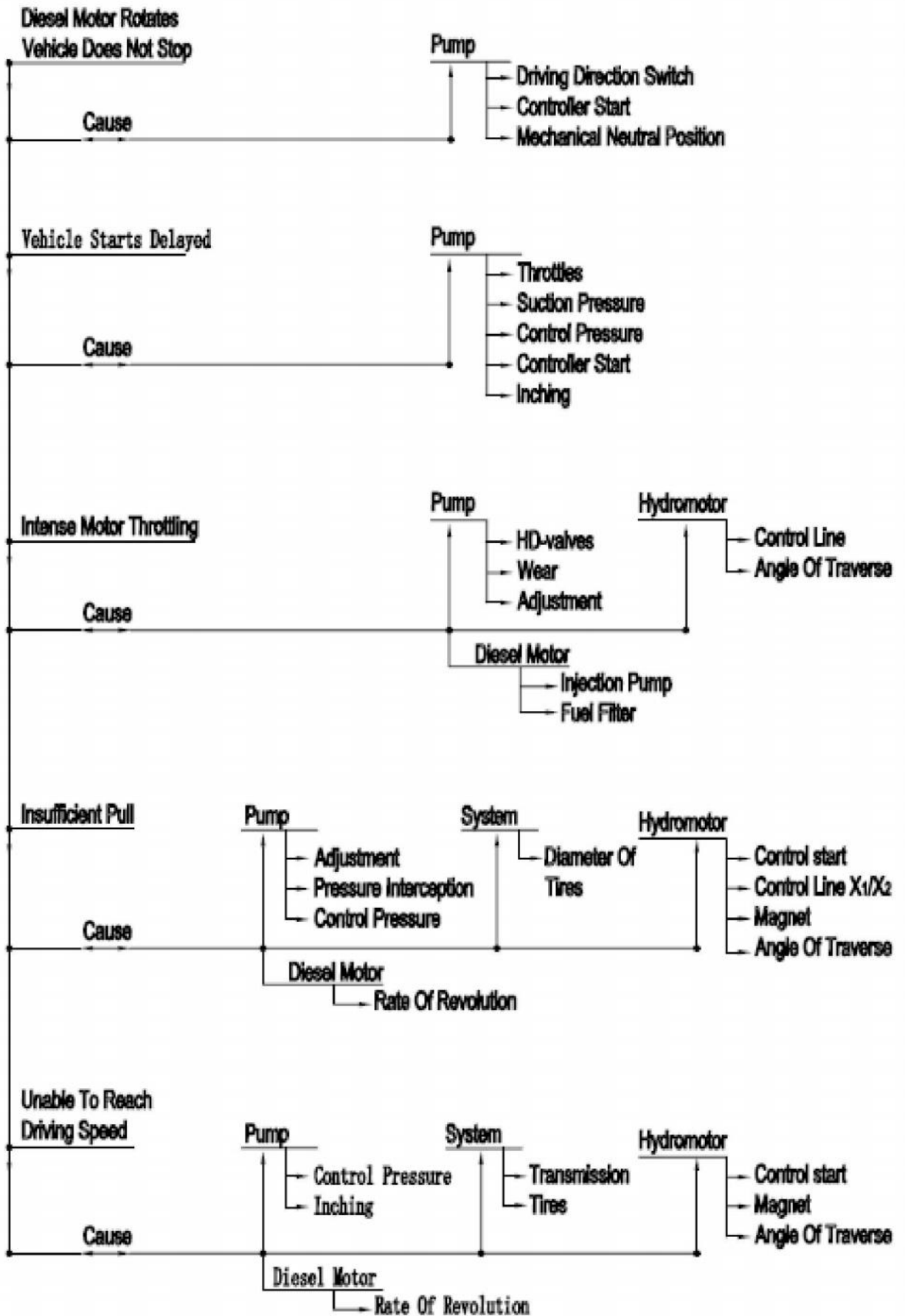

24 CAPACITIES AND FUEL AND OIL TYPES

24.1 Capacities

24.1.1 ER1000

Item	Capacity(litre)	Liquid/Lubrication Nipple	Specification
Fuel	21	Diesel	Standard DIN 51601 See Engine Operating Manual
Engine Oil With Filter	4	Engine Oil SAE 15w/40 Ambient Temp. -20°C -More Than 30°C	API CD, See Engine Operating Manual
Capacity Of Complete Axle	1.5	Gear Oil SAE 85w 90gl5	Hypoid
Complete Hydraulic System	26.5	Hydraulic Oil HLP	ISO VG46 (See Selection Chart)
Hydraulic Tank	18	Hydraulic Oil HLP	ISO VG46 (See Selection Chart)
Grease Points		Multipurpose Grease	Water Resistant
Contents Of Cooling System	4.3		



ATTENTION!!!

FOR ALL HAIYATE VEHICLES, WE RECOMMEND THE FOLLOWING

OIL TYPES:

GEAR OIL AFI-GL 5

FUCHS RENOGIER LS

80W90 / 85W90

24.2 Hydraulic Fluids (Mineral Oil Based)

ISO Viscosity Class	VG32	VG32	VG46*2	VG46	VG68	VG68
	HV	HLP	HV	HLP	HV	HLP
	VG32= winter conditions		VG46= summer conditions		VG68= tropical conditions	

Manufacturer						
			1st filling by HAIYATE			
AGIP	_	OSO32	Arnica 645	OSO46	_	OSO68
Aral,Vitam	HF32	GF32 DE32	HF46	GF46 DE46	_	GF68
AVIVA,Avilub	HVI32	RSL32	HVI46	RSL46	HVI68	RSL68
BP,Energol	SHF32	HLP32 HLP-D32	SHF46	HLP46 HLP-D46	_	HLP68 HLP-D68
Catrol,Hyspin	AWH32	AWS32	AWH46	AWS46	AWH68	AWS68
Cheron,EP Oil	32HV	OIL32	_	Oil46	68HV	Oil68
DEFROL	HVP32	HLP32	HVP46	HLP46	HVP68	HLP68
ESSO	UNIVI J32	Nuto H32	UNIVI N56	Nuto H46	UNIVI N68	Nuto H68
FINA,Hydran	HV32	32	HV46	46	HV68	68
FUCHS,Renolin	MR520	MR10B10	MR1030	MR15B15	_	MR20B20
Optimol,Hydo	MV5035	5035	MV5045	5045	MV5065	5065
MOBIL	DTE13	DTE24HLPD32	DTE15	DTE25HLPD46	DTE16	DTE26HLP D68
BP	HLP-M32	HLP32	HLP-M46	HLP46	_	HLP68
SHELL	Tell.T32	Tellus32	Tell.T46	Tellus46	Tell.T68	Tellus68
Texaco,Rando	HDAZ-32	HAD-32	_	HDB-46	HDCZ-68	HDC-68
VALVOLINE	_	ETC25	_	ETC30	_	ETC35
VEEDOL	_	_	_	Andarin46	_	Andarin55
HD-Engine Oil	_	SAE10W	SAE10W30		SAE10W30	SAE20W20

*1)for API-CC/SE or CD or MIL-L-46152 or MIL-L-2104C

*2)all ATF-specifications with FZG test load stage ≥ 10 ; as well as HD engine oil SAE 10W30

24.3 Environmentally Friendly Hydraulic Fluids

Selection Chart-only after prior agreement of the manufacturer

HETG,HEPG,HEE for axial piston vehicles.

Type	Synthetic Hydraulic Fluid	On Basis Of Estern, HEE	
ISO-Viscosity Class	VG32	VG46	VG68
Manufacturer			
ARAL		EHF 46 Vitam	
ASEOL		Terra 46	Terra 68
AGIP		Agip arnica S46	Agip arnica S68
AVIA		Avia Syntofluid 46	Avia Syntofluid 68
BECEM	Hydrostar TMP 32	Hydrostar TMP 46	Hydrostar TMP 68
BLASER		Blasol LP8905	
BP		Biohyd 46 SE	Biohyd 68 SE
BUCHER&CIE MOTOREX	Oekosynt2246		
DEA		Econa E46	
ELF		Hydrelf Bio46	
ESSO		EGL 45947	
FINA	Biohydran TMP32	Biohydran TMP 46	Biohydran TMP 68
FUCHS	Plantohyd S32	Plantohyd S46	Plantohyd S68
GLOBOIL	BHF32	BHF 46	BHF68
KENDALLDemmler& Co.,Switzerland		Synth. Natura 46 HV	
Kuwati Petrol Q8	Holbein 32	Holbein 46	
Molyduval	Chemlube 5126		
BP	Biohyd MT 32 MS32	Biohyd MT46 MS46	Biohyd MS68
OEST		Bio Synth.HYD 46	
PANOLIN,Switzerland	HLP Synth 32	HLP Synth 46	HLP Synth 68
QUAKER Chemical		Quintolubric Greensalve46	
RAISION TEHTAAT, Finland TEBIOL, Germany New Process, CH		Ester hyd HE46	
SHELL		Naturelle HF-E 46	
Strub & Co	Hydrosint HLP ISO 32	Hydrosint HLP ISO 46	Hydrosint HLP ISO 68

Type	Synthetic Fluid	Hydraulic	On Basis Of Estern, HEE	
ISO-Viscosity Class	VG32		VG46	VG68
Manufacturer				
TOTAL			Equivis Bio 46	68
Wenzel&HAIYATE			Ukabiol HE 46	
Westfalen AG			Bio-Forbex E46	
YORK Ginouves			LT 777Bio	

The above chart does not claim to be complete and contains no recommendations. Subject to alterations!



CAUTION!

WHEN CHANGING TO ENVIRONMENTALLY FRIENDLY HYDRAULIC FLUIDS, THE HYDRAULIC SYSTEM MUST BE FLUSHED SEVERAL TIMES. DO NOT MIX WITH MINERAL OIL!

25 LUBRICATION SCHEDULE

Lubricate all lubrication points daily with water-resistant multipurpose grease.

Lubricate all movable parts, such as parking brake lever, foot pedals, Bowden cables etc with an oilcan!

NOTE:

MAKE SURE THAT ALL STEERING CYLINDER LUBRICATION NIPPLES ARE LUBRICATED!!

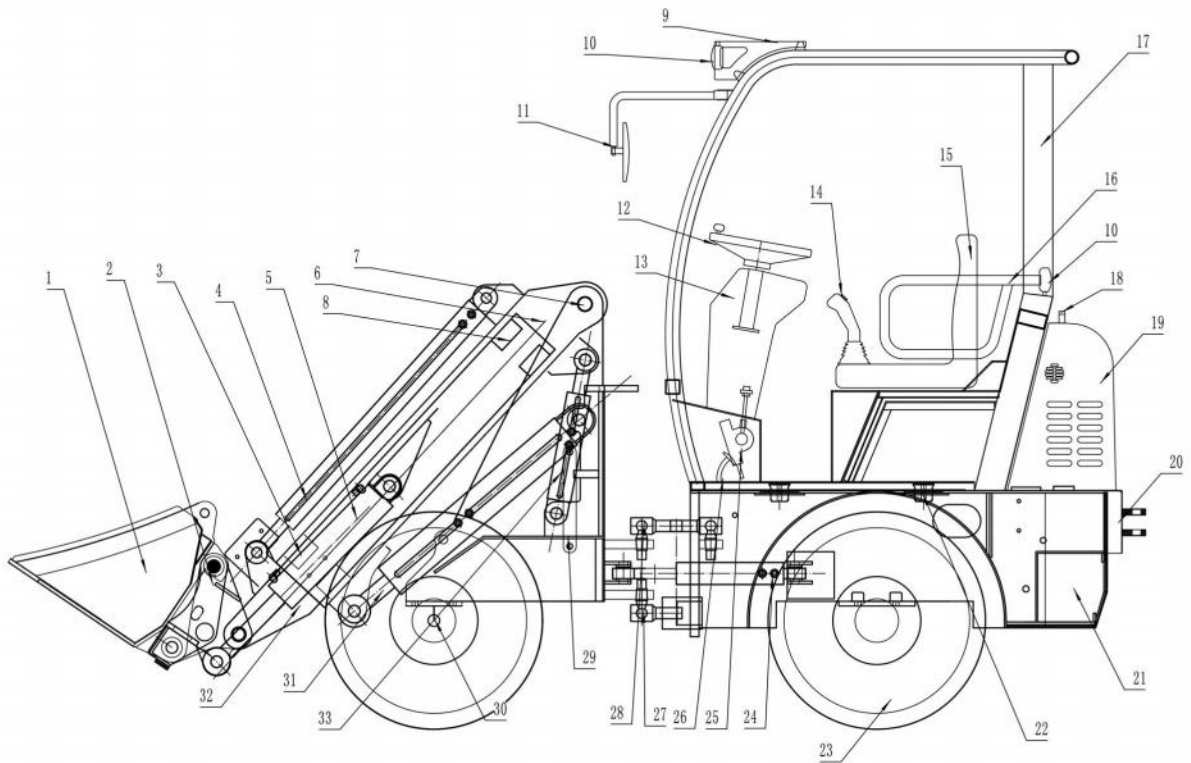

NO.	PART NO.	NAME	NAME	QUTY	REMARK
1	ER1000-010000	铲斗总成	shovel assembly	1	
2	ER1000-020000	快换总成	quick change assembly	1	
3	ER1000-030000	外臂滑块	outer slider	4	
4	ER1000-040000	伸缩油缸	telescopic cylinder	1	
5	ER1000-050000	翻斗油缸	dumper cylinder	1	
6	ER1000-060000	外臂	outer arm	1	
7	ER1000-070000	外臂销轴	outer arm pin	1	
8	ER1000-080000	内臂滑块	linner slider	4	
9	ER1000-090000	护网	protective net	1	
10	ER1000-100000	顶灯	top light	2	
11	ER1000-110000	后视镜	rearview mirror	2	
12	ER1000-120000	方向盘	steering wheel	1	
13	ER1000-130000	仪表总成	meter assembly	1	
14	ER1000-140000	先导手柄	pilot handle	1	
15	ER1000-150000	座椅总成	chair assmbly	1	
16	ER1000-160000	扶手	handrail	2	
17	ER1000-170000	简易棚总成	simple shed assmbly	1	
18	ER1000-180000	把手	handel	1	
19	ER1000-190000	后机罩	rear hood	1	
20	ER1000-200000	配重	counterweight	1	
21	ER1000-210000	蓄电池	battey	1	
22	ER1000-220000	减震垫	shock pad	4	
23	ER1000-230000	轮胎总成	tire assembly	4	
24	ER1000-240000	转向油缸	steering cylinder	1	
25	ER1000-250000	寸进软轴	inching flexble shaft	1	
26	ER1000-260000	刹车踏板	brake pedal	1	
27	ER1000-270000	下铰接球头	lower catenation	1	
28	ER1000-280000	上铰接球头	upper catenation	1	
29	ER1000-290000	锁止杆	locking lever	1	
30	ER1000-300000	驱动桥	drive axle	2	
31	ER1000-310000	举升油缸	lifting cylinder	1	
32	ER1000-320000	内臂	linner arm	1	
33	ER1000-330000	平衡油缸	counterbalance cylinder	1	
	ER1000-070000				

26 TYRE PRESSURE

Designation	P.R.	ET	Max. admissible Air Pressure (bar)
27*8.5-15 TL	6	39	3.4
27*8.5-15 TL	6	29	3.4

27 ORDERING OF SPARE PARTS

When you order spare parts, please give the following information to guarantee a smooth handling of your order and delivery.

- 1 HAIYATE vehicle type
- 2 Vehicle and chassis identification number (see identification plate) and the corresponding engine number
- 3 Article number and nomenclature of the spare part
- 4 Your address and telephone number (for eventual queries)
- 5 Customer-number (if any)
- 6 Name of the person placing order
- 7 Mode of dispatch (please see below)

Please note that the illustrations in our spare parts lists may not always be a true representation of the corresponding original part. We reserve the right of modification for technical improvements.

Parts for which the article number is not known, should be sent to HAIYATE as an example to avoid incorrect deliveries. Parts which are not requested to be returned will be scrapped.

Please inform us of your address if you are a new customer, so that the correct processing of subsequent deliveries can be guaranteed. For initial orders, the goods are sent cash on delivery.

Parts must be returned prepaid, when, for particular reasons a free compensation is requested.

Please do not forget to indicate the mode of dispatch desired when ordering:

- 1、 Overnight
- 2、 parcel service
- 3、 haulage

Use only original HAIYATE spare parts which have been produced in our works and guarantee an optimal installation and an excellent quality.

28 Hydraulic Schematic

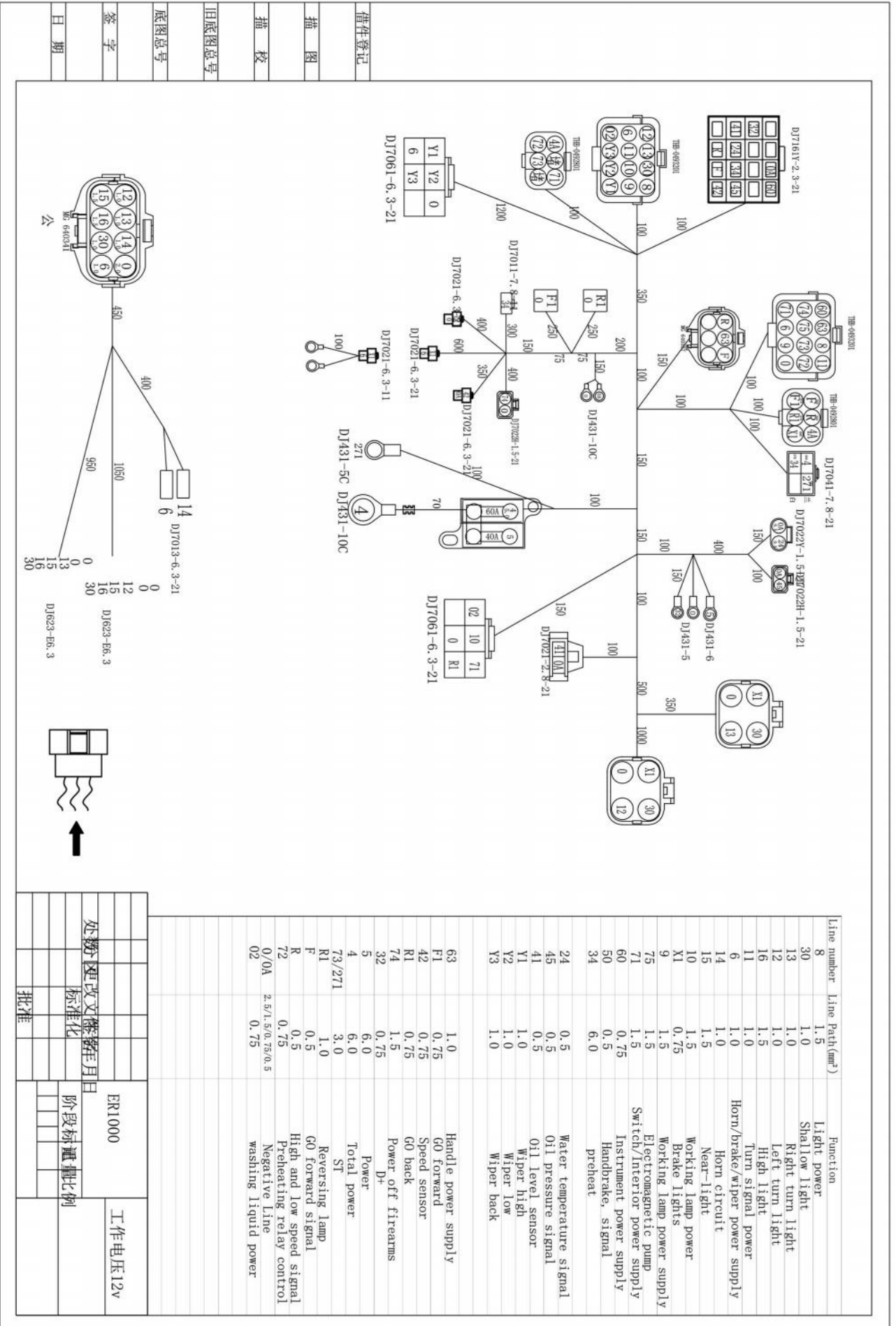

零件登记
 插图
 描校
 旧底图总号
 底图总号
 签字
 日期

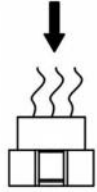
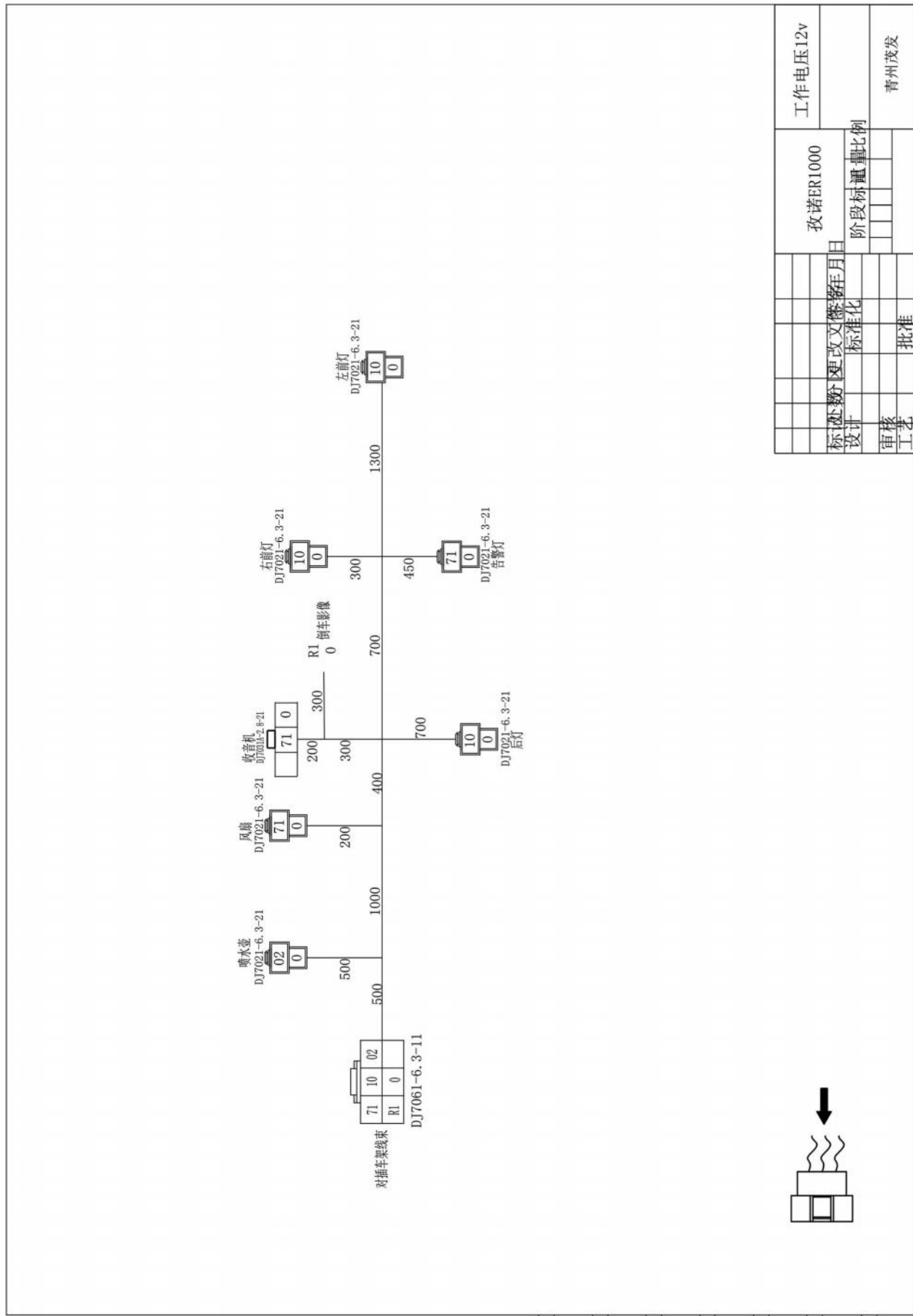

借件登记	
描图	
描校	
旧底图总号	
底图总号	
签字	
日期	

工作电压12v	
致诺ER1000	
标准	更改日期
设计	标准化
审核	阶段标准
工艺	比例
批准	
青州茂发	

